

REVISIONS				
ECO	REV.	DESCRIPTION	DATE	APPROVED
	A	INITIAL RELEASE		

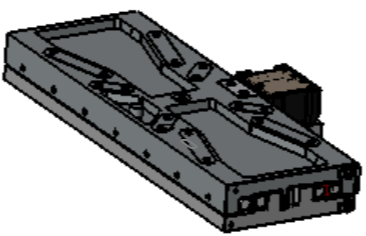
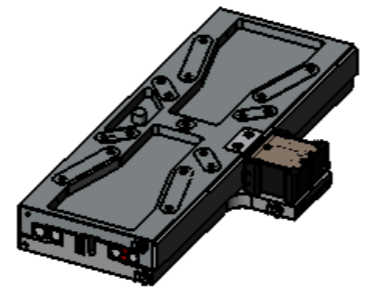
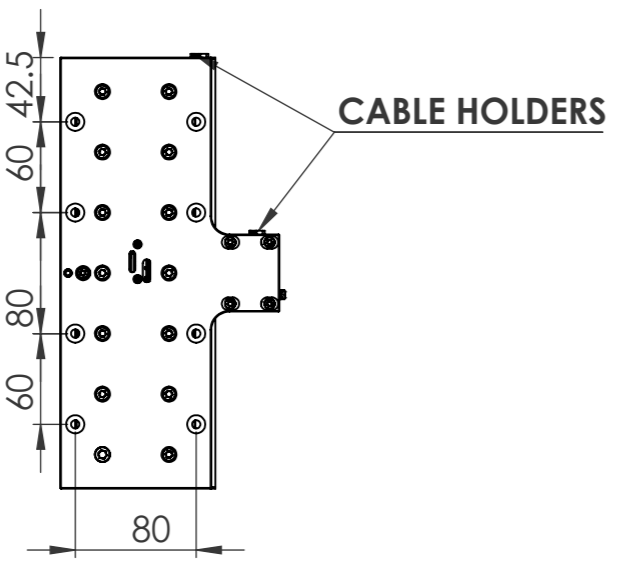
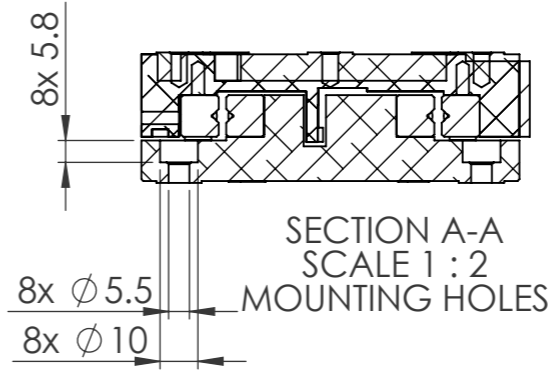
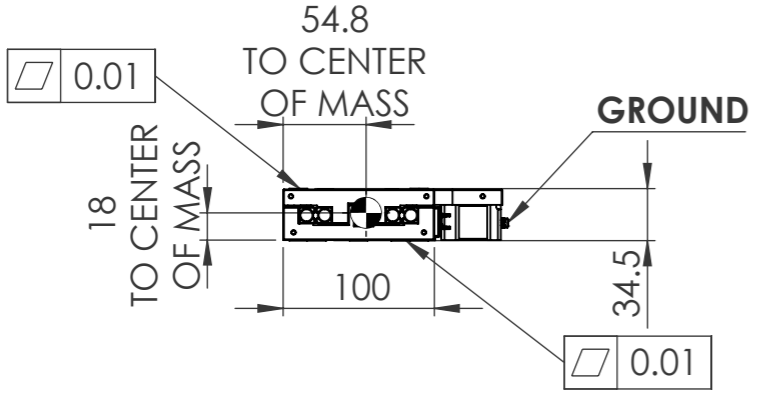
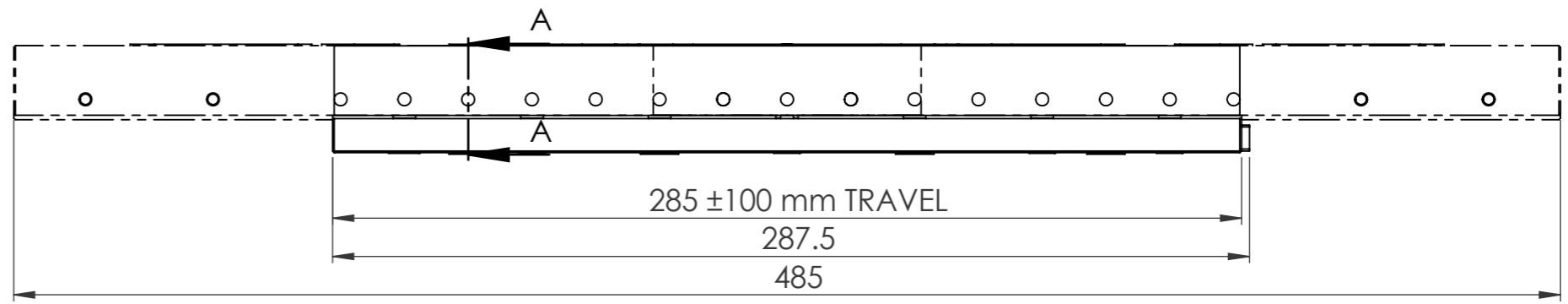
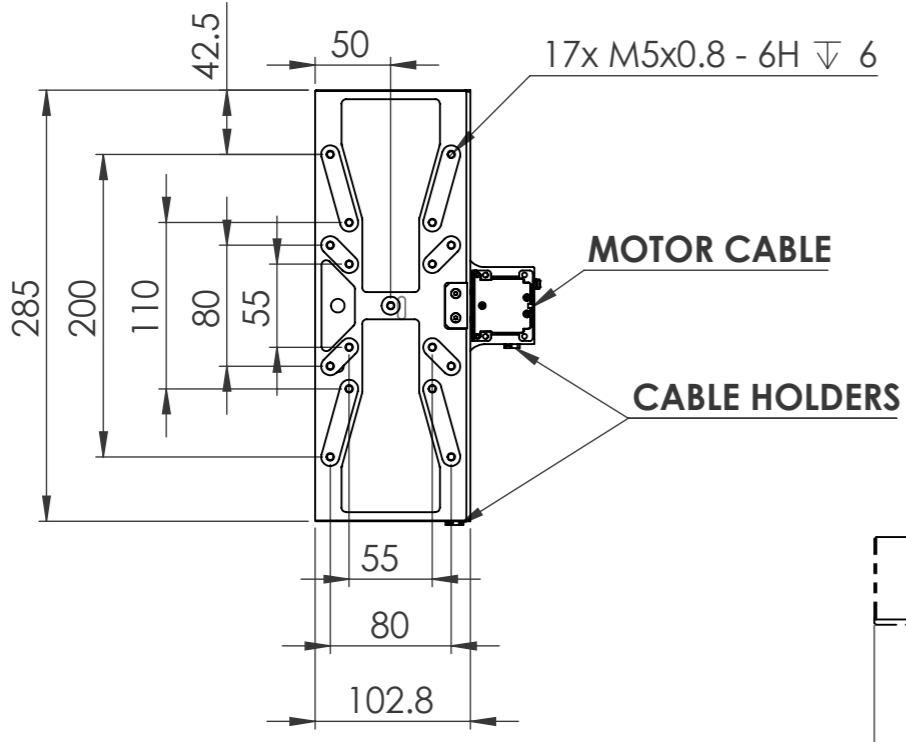

Copyright by NANOMOTION Ltd. ALL RIGHTS RESERVED! This drawing contains confidential & proprietary information which the authorised recipient agrees & not to disclose.

MATERIAL: N.A.

FINISH:

ALL DIMENSIONS UNIT: mm

SURFACE ROUGHNESS: ∇ N7

FIRST ANGLE PROJECTION

GENERAL TOLERANCES ACCORDING TO ISO 2768-FH REFERENCE TABLE		
NOMINAL MEASURE	TOLERANCE	
0 - 6	\pm 0.1*	
6 - 30	\pm 0.1	
30 - 120	\pm 0.15	
120 - 400	\pm 0.2	

*TOLERANCES DIFFER FROM ISO 2768-FH

PROJECT:

PART NAME:

PART NUMBER:

REV.

SCALE 1:5

DWG. SIZE A3

SHEET 1 OF 2

DESIGNED	CHECKED	APPROVED	NAME	SIGNATURE	DATE

TECHNICAL SPECIFICATIONS:

Mechanical Design Characteristics	
Stage Plate Structure	Aluminum - Black Anodize
Motor	Piezo Electric, Ultrasonic Standing Wave HR8
Linear Bearings	Precision crossed roller with anti-migration device
Encoder	Linear optical scale with 20µm signal period and 0.1µm resolution, with home reference mark with electrical limits
Cable Lengths	3m
MTBF	30,000 hours
Stage Mass (g)	2945
Moving Mass (g)	1200

Performance Specifications	
Travel Range (mm)	200
Encoder Resolution (µm)	0.1 standard; (10nm optional)
Bi-directional Repeatability (µm)	1.0 standard; (0.1µm optional)
Maximum Velocity (mm/sec)	250
Straightness & Flatness (µm)	+/- 4
Pitch & Yaw (µrad)	+/- 50
Load Capacity(Horizontal) (kg)	2.35
Load Capacity (vertical lift) (kg)	N/A
Dynamic Stall Force (N)	32
Stage Stiffness (N/µ)	3.15

MOTOR CONECTOR- 9 pin D-type female		
Pin	Function	Description
1	GND	System ground
2	N.C.	With AB1A Driver - Phase
3	Motor-Up	White wire - High voltage input
4	Motor-Common	Black wire - High Voltage input for AB1A, GND for AB5 AB2 and AB4 drivers as well as XCD Controller/Drivers
5	Motor-Down	Red wire - High voltage input
6	Motor-Connected Safety input	Short pin 6 to pin 1 - enables Driver. Open on pin 6 - disables the Driver.
7	GND	System ground - Connected to connector hood
8	N.C.	Not connected
9	N.C.	Not connected

ENCODER CONNECTOR- D-Type 15 pin, MALE		
Pin #	Pin Name	Function
7,8	5V	Power
2,9	0V	
14	A+	Incremental signals
6	A-	
13	B+	
5	B-	Reference mark / Index
12	Z+/Q-	
4	Z-/Q+	Inner shield
15	Shield	
Case	Shield	Outer shield
1,3	N.C.	Not connected
10-11	N.C.	Not connected



PART NUMBER: _____ REV. _____

SCALE 1:2 DWG. SIZE A3 SHEET 2 OF 2