

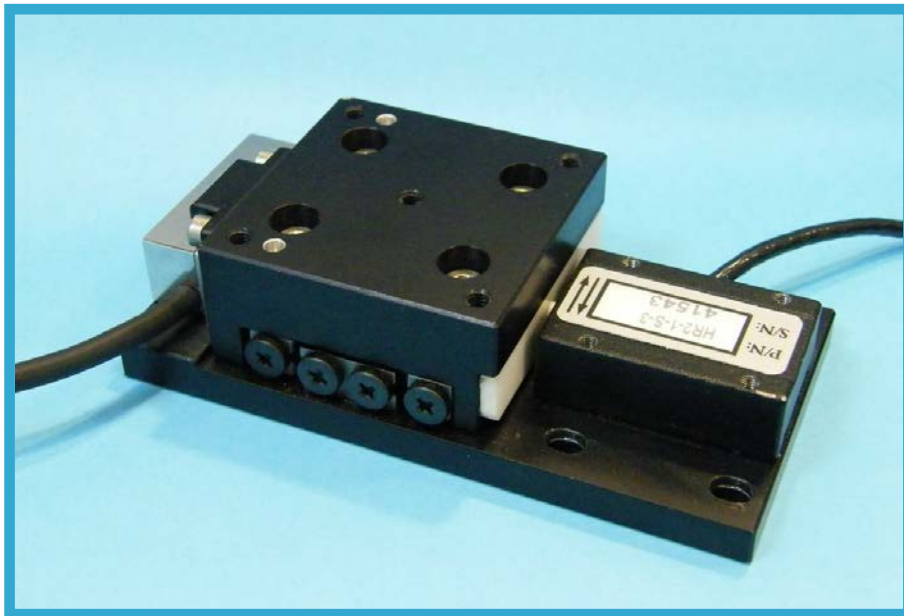

A Johnson Electric Company

FB Positioning Systems User Guide



FB00458000-01 REV:B

August 29, 2012

Nanomotion Ltd. POB 623, Yokneam 20692, Israel

Tel: 972-73-2498000 Fax: 972-73-2498099

Web Site: www.nanomotion.com

E-mail: nano@nanomotion.com

Copyright

This document contains proprietary information of Nanomotion Ltd., and may not be reproduced in any form without prior written consent from Nanomotion Ltd.

No part of this document may be reproduced, translated, stored in a retrieval system or transmitted in any form and by any means, electronic, mechanical, photographic, photocopying, recording, or otherwise, without the written permission of Nanomotion Ltd.

Information provided in this document is subject to change without notice and does not represent a commitment on the part of Nanomotion Ltd.

Copyright 2009 - 2012, Yokneam, Israel. All rights reserved.

All products and company names are trademarks or registered trademarks of their respective holders.

Limited Warranty

Nanomotion Ltd. (hereinafter NM) warrants the product (other than software) manufactured by it to be free from defects in material and workmanship for a period of time of one year (except those parts normally considered as consumable/expendable components such as motor conditioning brushes). The warranty commences thirty (30) days from the date of shipment.

NM warrants those parts replaced under warranty for a period equal to the remaining warranty coverage of the original part.

NM's sole and exclusive obligation under this warranty provision shall be to repair, or at its sole option exchange defective products or the relevant part or component, but only if: (i) the Purchaser reports the defect to NM in writing and provides a description of the defective product and complete information about the manner of its discovery within ten (10) days of its discovery; (ii) NM has the opportunity to investigate the reported defect and to determine that the defect arises from faulty material, parts or workmanship; and (iii) the Purchaser returns the affected product to a location designated by NM. These provisions constitute the exclusive remedy of the Purchaser for product defects or any other claim of liability in connection with the purchase or use of NM products.

This warranty policy applies only to NM products purchased directly from NM or from an authorized NM distributor or representative.

This warranty shall not apply to (i) products repaired or altered by anyone other than those authorized by NM; (ii) products subjected to negligence, accidents or damage by circumstances beyond NM control; (iii) product subjected to improper operation or maintenance (i.e. operation not in accordance with NM Installation Manuals and/or instructions) or for use other than the original purpose for which the product was designed to be used.

NM shall not in any event have obligations or liabilities to the Purchaser or any other party for loss of profits, loss of use or incidental, increased cost of operation or delays in operation, special or consequential damages, whether based on contract, tort (including negligence), strict liability, or any other theory or form of action, even if NM has been advised of the possibility thereof, arising out of or in connection with the manufacture, sale, delivery, use, repair or performance of the NM products. Without limiting the generality of the preceding sentence, NM shall not be liable to the Purchaser for personal injury or property damages.

Patent Information

Nanomotion products are covered under one or more of the following registered or applied for patents.

5,453,653; 5,616,980; 5,714,833; 111597; 5,640,063; 6,247,338; 6,244,076;
6,747,391; 6,661,153; 69838991.3; 6,384,515; 7,119,477; 7,075,211;
69932359.5; 1186063; 7,211,929; 69941195.5; 1577961; 4813708; 6,879,085;
6,979,936; 7,439,652; 7061158 ;1800356; 1800356; 1800356; 2007-533057
(pending); 2011-093431 (pending); 7,876,509; 10-2007-7009928 (pending);
200780019448.6 ; 7713361.9 (pending); 12/294,926 (pending); GB2008000004178
(pending); GB2009000003796 (pending); 12/398,216 (pending); GB2446428;

12/517,261 (pending); 08702695.1 (pending); 10-2009-7017629 (pending);
12/524,164 (pending); 12/581,194 (pending)

Revision History

Revision	Release date	Details
00/A	Apr 2009	New release
01/A	Jan 2011	Added UHV connection wires schema. Added an "Important" note as to run the system before operation. Added details about configurations which include interpolator. Added updated EOP information.
01/B	Feb 2011	Updated the "Stage Heat Dissipation considerations" section semantics
NA	Aug. 2012	Administrative change – added patent information section in front matter.

Table of Contents

1	PREFACE	9
1.1	About This User Guide	9
1.2	Who Should Use This User Guide	9
1.3	Nanomotion Products Reference Documentation	9
1.4	Safety Precautions	10
2	FB SERIES	11
2.1	Introduction	11
2.2	Features	11
2.3	Stage Configurations	11
2.4	Available Configurable Assemblies	12
2.5	Encoder Options.....	12
3	QUICK START	13
3.1	Unpacking the Stage	13
3.2	Stage Installation.....	14
3.3	Connecting and Turning On the System.....	15
4	MECHANICAL DRAWINGS	18
4.1	FB050 Layout.....	18
4.2	FB075 Layout.....	19
4.3	FB100 Layout.....	20
4.4	FB150 Layout.....	21
5	TECHNICAL SPECIFICATIONS	22
5.1	Straightness and Flatness	22
5.2	Maximum Load Capacity	22
5.3	Position Repeatability	22
5.4	FB050 Series	23
5.5	FB075 Series	23
5.6	FB100 Series	24

5.7 FB150 Series 24

6 MOTOR DYNAMIC PERFORMANCE..... 25

6.1 Settling Time 25

6.2 Thermal Envelope of Performance (EOP) for HR Motors 26

6.3 Standard Motor Connector Pinout 35

6.4 Ultra-High Vacuum Motor Connection Wires 37

6.5 A Quad B Encoder Connector Pinout 38

6.6 Sin/Cos Encoder Connector Pinout 38

7 ORDERING INFORMATION 39

7.1 Part Numbering Scheme 39

7.2 Example Configurations 39

8 CONTACT INFORMATION..... 40

8.1 Customer Service 40

8.2 General Inquiries and Ordering 40

List of Figures

Figure 1: Removing the Shipping Bracket	13
Figure 2: FB050 Stage Layout	18
Figure 3: FB075 Stage Layout	19
Figure 4: FB100 Stage Layout	20
Figure 5: FB150 Stage Layout	21
Figure 13: Motor Velocity vs. Command.....	28
Figure 14: Motor Force vs. Velocity at the Various Work Regimes (a-g).....	29
Figure 15: Velocity vs. Command Using the AB5/AB51 Driver	31
Figure 16: Force vs. Velocity Using the AB5/AB51 Driver at the Various Work Regimes (a-h).....	32
Figure 6: Standard Motor Connector	35
Figure 7: UHV Motor Connection Wires	37

1 Preface

1.1 About This User Guide

This user guide provides instructions for unpacking, connecting and operating the FB positioning system. It also includes details of the various Nanomotion FB positioning systems' available configurations, motor performance specifications and mechanical layouts. For user's convenience, the FB positioning system is referred to as stage, further in this user guide.

1.2 Who Should Use This User Guide

This user guide is intended for engineers or technicians, directly involved in installation, operation and maintenance of positioning systems and control systems.

Before starting the procedure outlined in this user guide, make sure that you read the Safety Precautions section outlined below and follow all safety guidelines as described further on in this user guide.

1.3 Nanomotion Products Reference

Documentation

The following documents contain additional information, related to the FB Positioning Systems, which can be found on Nanomotion website as well:

- AB5 and AB51 Drivers User Manual
- AB1A / AB2 / AB4 Driver User Manuals
- FlexDC Controller HW User Manual (includes Quick Start!)
- FlexDC Controller SW User Manual
- HR2 / HR4 / HR8 Motor User Manuals
- Nanomotion Vacuum and Ultra High Vacuum Motors Bake-out Procedure.

1.4 Safety Precautions



WARNING!

- Do not remove the cover of the motor or disassemble its connector. High voltage hazard!
- Before operating the stage, ensure that the motors are grounded.



CAUTION:

- Ensure that the stage is not subjected to mechanical shock.
- Do not immerse the stage in any liquid or cleaning agent. Use only a clean cloth to wipe the stage.
- The HR motors are not user-serviceable.
- In case the motor had been remounted, perform the conditioning procedure (refer to motor user manual).
- Follow the Quick Start instructions provided in this guide before operating the stage.
- Motor operation must adhere to a specific duty cycle (refer to motor user manual or refer to the EOP chapter, further in this user guide).

2 FB Series

2.1 Introduction

The FB series product line is a family of standard linear positioning systems (stages), designed for modular single and multi-axis, applications. The stage configuration utilizes cross roller bearings, a linear optical encoder and Nanomotion ceramic servo motors. The stages are offered in a wide range of widths and travel lengths and encoder resolutions to achieve a range of performance criteria. Various motors sizes are available for each configuration to meet necessary force/acceleration requirements.

2.2 Features

- Compact stage design with low profile.
- Direct drive motor with simple, robust construction.
- Linear encoder mounted in the center for optimum positioning (eliminating Abby Error).
- Easily configurable in multi-axis.
- Wide range of slide sizes, travels and motor sizes.

2.3 Stage Configurations

Series	Width	Motor Options	Standard Travels (mm)
FB050	50 mm	HR2 or HR4	20, 50, 75
FB075	75 mm	HR4 or HR8	40, 60, 100, 150
FB100	100 mm	HR4 or HR8	60, 100, 150, 200, 300
FB150	150 mm	HR4 or HR8	100, 150, 200, 300

2.4 Available Configurable Assemblies

Nanomotion supplies the FB stages in following multi-axes configurations:

- X/Y
- X/Z using angle bracket
- X/Y/Z using angle bracket
- Vacuum versions available

Nanomotion also configures assemblies with integrated Theta and Goniometer stages providing rotation/tip/tilt. Contact Nanomotion technical support for more information, see chapter 8.



IMPORTANT:

- **Nanomotion supplies lubricated vacuum and ultra high vacuum stages by means of "Apiezon® Grease, Type M" high vacuum grease. Other type of grease is optional.**
- **Each stage has integrated non-adjustable mechanical hard stops.**

2.5 Encoder Options

Encoder Resolution ⁽¹⁾	Optional / Standard	Reference Mark ⁽²⁾	External Interpolator Box ⁽³⁾
1 µm	Optional	Included	--
0.5 µm	Optional	Included	--
0.1 µm	Standard	Included	--
50 nm	Optional	Included	Included
10 nm	Optional	Included	Included
Analog output (Sin/Cos)	Optional	Included	--



Notes:

- (1) All standard FB stages are provided with 0.1µm resolution linear encoders.
- (2) Reference Mark: magnetic non-adjustable Home Sensor.
- (3) All vacuum stages are supplied with an external interpolator box.

3 Quick Start

3.1 Unpacking the Stage

Nanomotion delivers the FB stage for vacuum environment double-bagged per Class1000 clean room standards. The non-vacuum FB stages are delivered in a Nanomotion standard packaging.

Non-vacuum FB stages with 50nm and 10nm encoder resolution and all vacuum FB stages include an external encoder interpolator box (interpolator), (see section 2.5).

- 3.1.1 All FB stages are delivered with their axes locked by shipping brackets. Before stage operation remove the shipping bracket by means of screwdriver, see Figure 1:

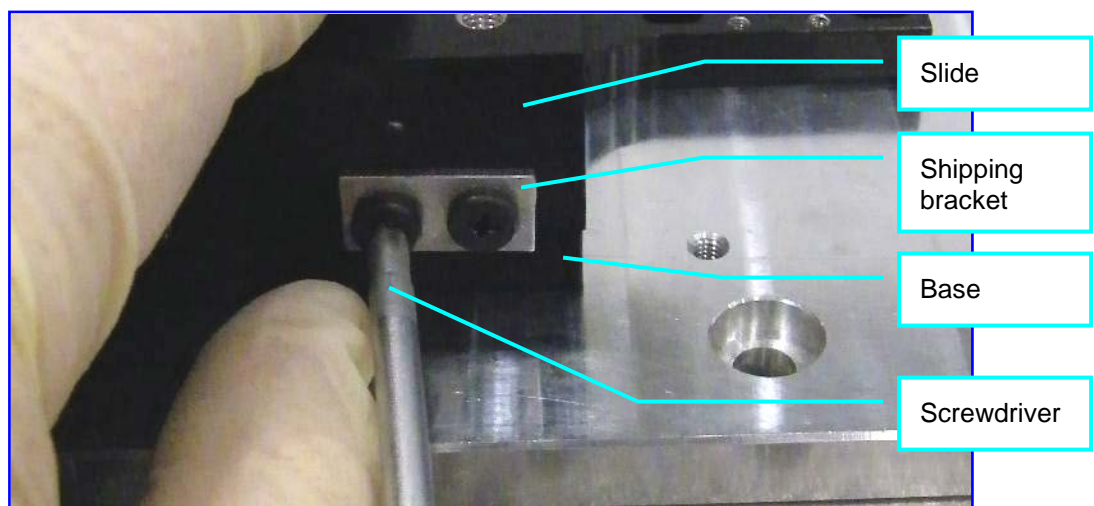

Figure 1: Removing the Shipping Bracket

- 3.1.2 After removing the shipping bracket, fasten the screws back to their original location at the end of the rail, by applying a proper torque.

3.2 Stage Installation



CAUTION

Install the stage in a location free of excessive vibration.

- 3.2.1 Attach the stage to a user-prepared mounting surface (refer to chapter 4 "Mechanical Drawings" for interface). The recommended level of flatness for attachment surface is **20µm or less**.
- 3.2.2 Attach the payload to the stage (refer to chapter 4 "Mechanical Drawings" for interface).

3.3 Connecting and Turning On the System



IMPORTANT:

- Make sure all stage motors and encoders are connected to the corresponding axis on the servo controller.
- The motors and the encoders are already aligned and adjusted by Nanomotion and their performance is verified.
- Nanomotion guarantees proper driver and motor performance only when using Nanomotion-supplied cables.
- Nanomotion supplies conditioned stages. Perform conditioning only in case a motor had been remounted (refer to motor user manual).
- As to vacuum (V) and ultra-high vacuum (UHV) stages: Nanomotion supplies clean V and UHV motors, yet the bake-out is required in order to remove residual contaminants and absorbed humidity from the motors and other system components. Refer to the "Nanomotion Vacuum and Ultra High Vacuum Motors Bake-out Procedure", D/N: HR00458001.



CAUTION:

- Shortening the motor cable length may damage the motor. Do not attempt to shorten the cable without prior confirmation by Nanomotion.
- Extending the motor cable does not damage the motor; however it might affect its performance.

-
- 3.3.1 Connect the motor to the Nanomotion driver (refer to driver user manual for more information). Refer to section 6.3 for Standard Motor Connector Pinout and section 6.4 for Ultra-High Vacuum Motor Connection Wires.
- The Motor_Connected interlock is available on Nanomotion standard motor connector. It disables high voltage on the bare driver output connector, when the motor disconnected from the driver.
 - Nanomotion's motors run at a resonant frequency and are sensitive to the capacitance of the electrical circuit. Changing cable length affects the total capacitance (refer to driver user manual for maximum allowed cable length).
 - Nanomotion provides motors with specific low capacitance cable as follows:
 - Standard motors: 210pF/meter
 - Vacuum motors: 43pF/meter
- 3.3.2 Connect the driver to the user's servo controller (refer to driver user manual and controller user manual for pinouts and interconnection information).
- 3.3.3 For stage configuration without the interpolator, skip to section 3.3.4, otherwise, perform steps (a) to (c) to connect the interpolator:
- (a) Connect the encoder output to the interpolator input (refer to section 6.5 for encoder's pinout).
 - (b) Connect the interpolator output (see section 6.5 for the A Quad B Encoder Connector Pinout) to the controller.
 - (c) Proceed to section 3.3.5.
- 3.3.4 Connect the encoder to the servo controller (refer to section 6.5 and section 6.6 for encoders' pinouts; refer to controller user manual for pinout and interconnection details).
- 3.3.5 Connect the servo controller to the PC.
- 3.3.6 Connect the proper external power supply to the driver (refer to the driver user manual for more information).

- 3.3.7 Connect the servo controller to power supply source (refer to the controller user manual for more information).
- 3.3.8 Before operating the stage, refer to the controller user manual for servo parameters tuning and operation instructions.
- 3.3.9 Turn the servo controller on (ensure there is no command when turning the power on).

**IMPORTANT:**

After unpacking the stage or if is unused for an extended period of time (over a week), run the stage with relaxed servo settings, several times, the whole travel, so it resumes its equilibrium.



CAUTION: Avoid prolonged operation in an unstable condition (excessive vibration and noise) during the tuning process.

4 Mechanical Drawings

4.1 FB050 Layout

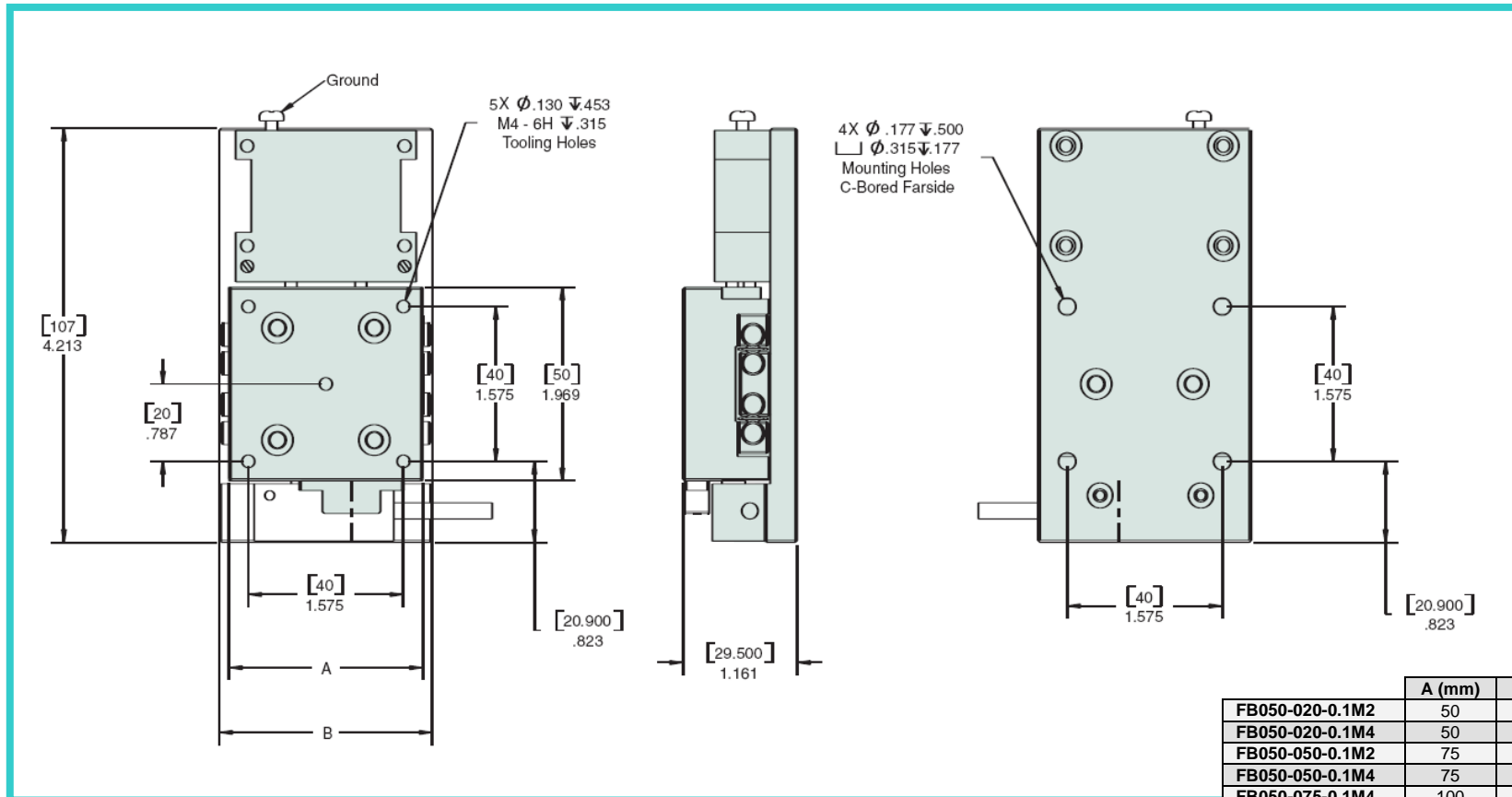

Figure 2: FB050 Stage Layout

4.2 FB075 Layout

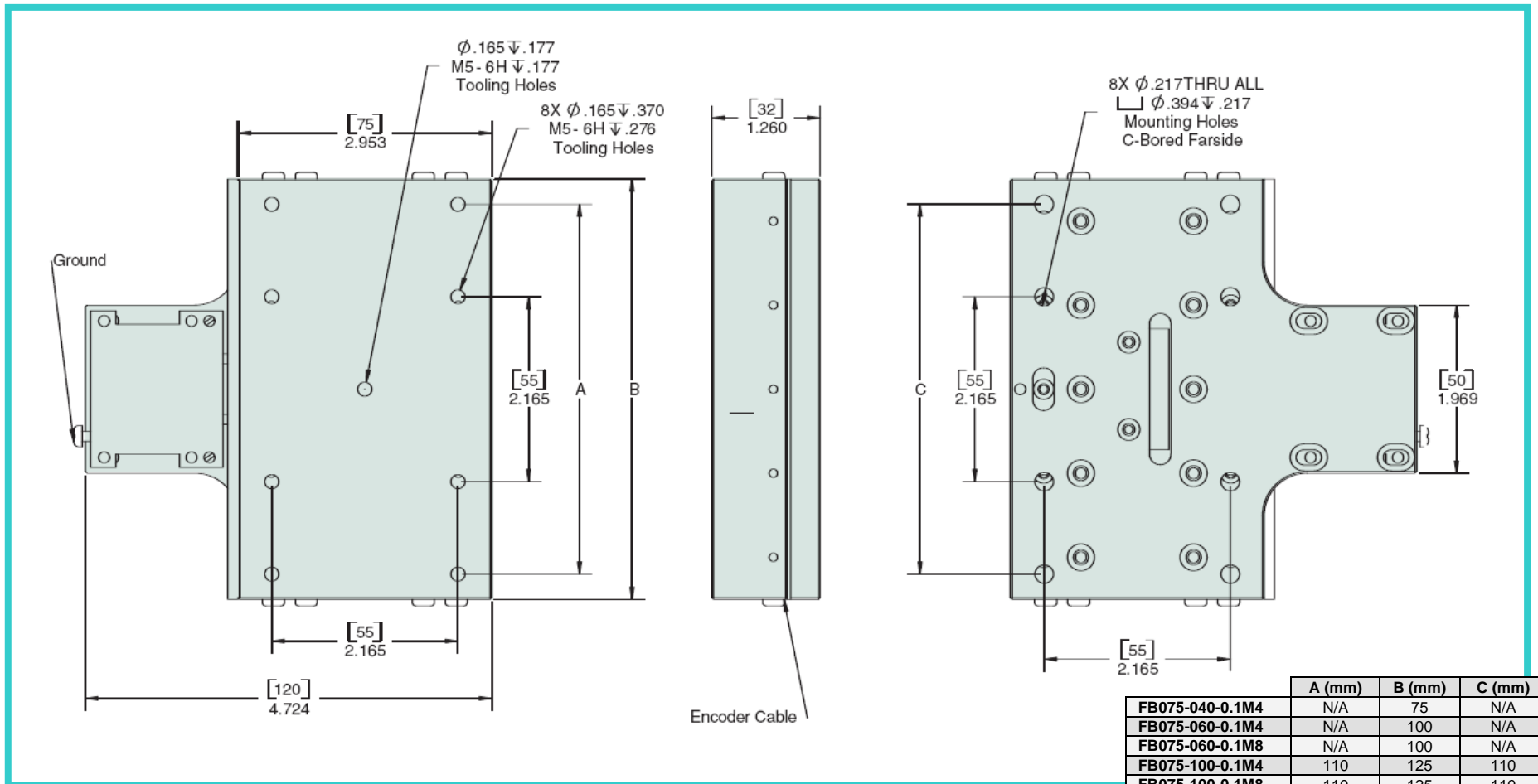

Figure 3: FB075 Stage Layout

4.3 FB100 Layout

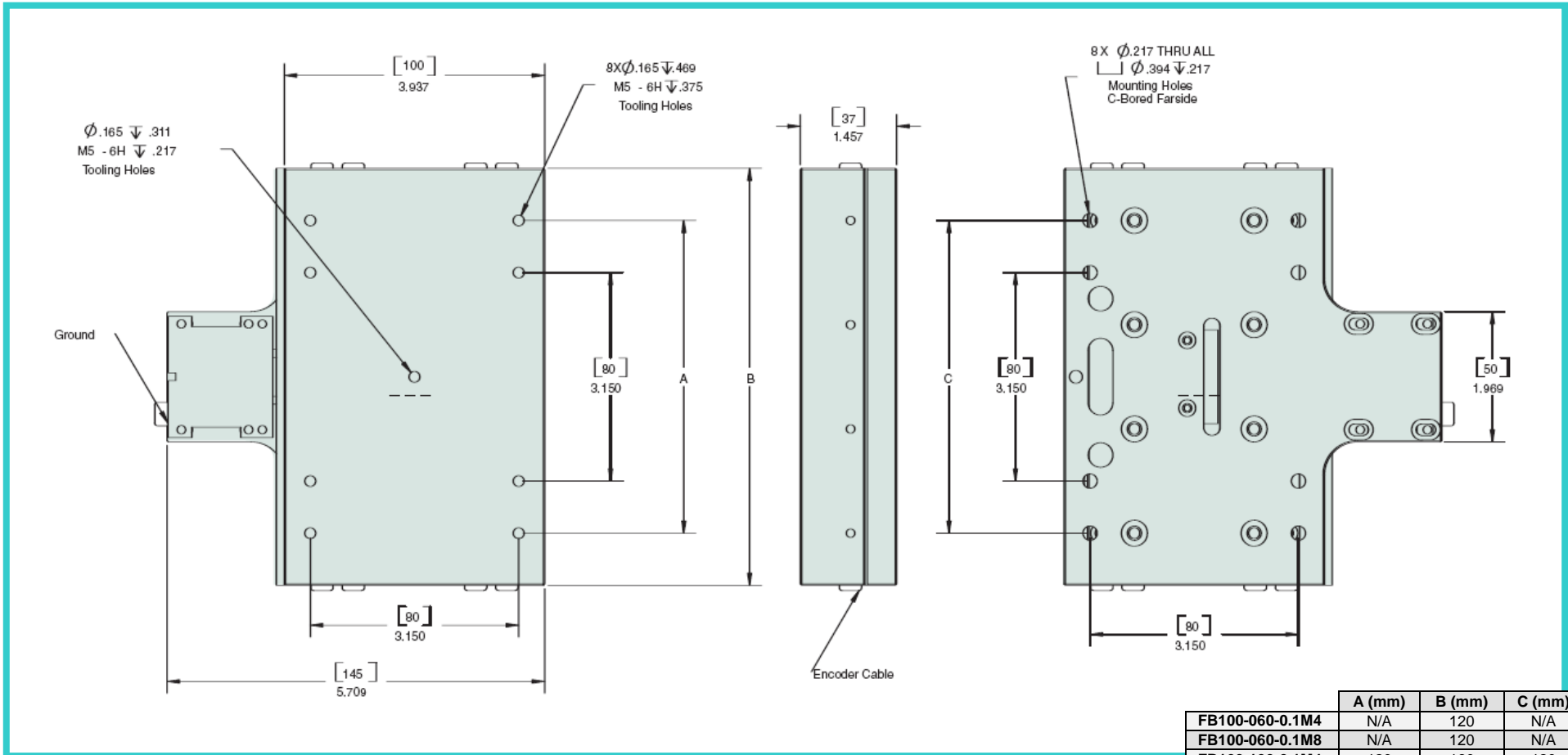

Figure 4: FB100 Stage Layout

4.4 FB150 Layout

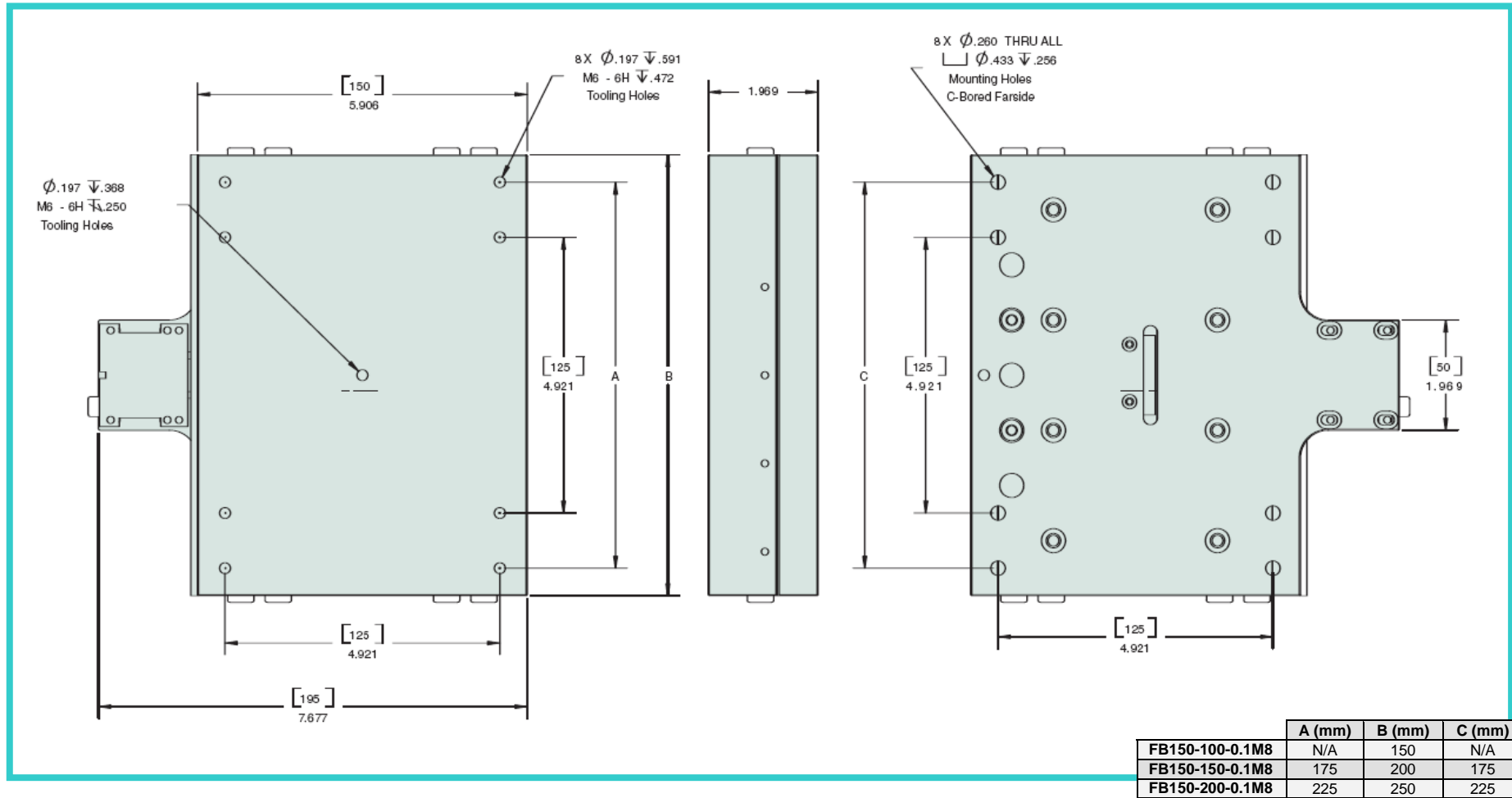

Figure 5: FB150 Stage Layout

5 Technical Specifications

5.1 Straightness and Flatness

	FB050	FB075	FB0100	FB150
Starightness & Flatness	2.5µm/25mm travel	2.5µm/25mm travel	2.5µm/25mm travel	1.5µm/25mm travel

5.2 Maximum Vertical Load Capacity

Travel (mm)	Maximum Vertical Load Capacity (kg)			
	FB050	FB075	FB0100	FB150
20	2	-	-	-
40	-	5	-	-
50	5	-	-	-
60	-	5	10	-
75	7	-	-	-
100	-	7	12	20
150	-	10	12	25
200	-	-	-	25

5.3 Position Repeatability

Encoder	FB050	FB075	FB0100	FB150
0.1µm standard	±0.5 µm			
10nm optional	±50 nm			
50nm optional	±200 nm			
0.5µm optional	±2 µm			
1.0µm optional	±3 µm			

5.4 FB050 Series Properties

	Travel (mm)	Stiffness “K”** (N/μ)	Dynamic Stall Force (N)*	Static Holding Force (N)*	Stage Mass (g)	Moving Mass (g)
FB050-020-0.1M2	20	1.8	8	7	385	150
FB050-020-0.1M4	20	2.8	16	14	400	150
FB050-050-0.1M2	50	1.8	8	7	595	266
FB050-050-0.1M4	50	2.8	16	14	610	266
FB050-075-0.1M4	75	2.8	16	14	700	400

* Specified values are within ±10% range.

** Refer to section 6.1 for Settling Time calculation.

5.5 FB075 Series Properties

	Travel (mm)	Stiffness “K”** (N/μ)	Dynamic Stall Force (N)*	Static Holding Force (N)*	Stage Mass (g)	Moving Mass (g)
FB075-040-0.1M4	40	2.8	16	14	650	302
FB075-060-0.1M4	60	2.8	16	14	920	405
FB075-060-0.1M8	60	3.5	30	28	1035	412
FB075-100-0.1M4	100	2.8	16	14	1125	505
FB075-100-0.1M8	100	3.5	30	28	1230	515
FB075-150-0.1M4	150	2.8	16	14	1515	710
FB075-150-0.1M8	150	3.5	30	28	1620	720

* The specified values are within ±10% range.

** Refer to section 6.1 for Settling Time calculation.

5.6 FB100 Series Properties

	Travel (mm)	Stiffness “K”** (N/μ)	Dynamic Stall Force (N) *	Static Holding Force (N)*	Stage Mass (g)	Moving Mass (g)
FB100-060-0.1M4	60	2.8	16	14	1580	690
FB100-060-0.1M8	60	3.5	30	28	1690	700
FB100-100-0.1M4	100	2.8	16	14	2040	920
FB100-100-0.1M8	100	3.5	30	28	2145	930
FB100-150-0.1M8	150	3.5	30	28	2625	1160
FB100-200-0.1M8	200	3.5	30	28	3500	1600

* The specified values are within $\pm 10\%$ range.

** Refer to section 6.1 for Settling Time calculation.

5.7 FB150 Series Properties

	Travel (mm)	Stiffness “K”** (N/μ)	Dynamic Stall Force (N) *	Static Holding Force (N)*	Stage Mass (g)	Moving Mass (g)
FB150-100-0.1M8	100	3.5	30	28	3940	1600
FB150-150-0.1M8	150	3.5	30	28	5095	2125
FB150-200-0.1M8	200	3.5	30	28	6275	2660

* The specified values are within $\pm 10\%$ range.

** Refer to section 6.1 for Settling Time calculation.

6 Motor Dynamic Performance

6.1 Settling Time

The achievable settling time is mainly dictated by the damping of the motor and the natural frequency of the system. A typical number of three cycles is required for the motor damping to damp the system vibration along the motion axis, so the settling time is roughly according to the following formula:

$$T_s = \frac{3}{Fr}$$

where **Fr** is the natural frequency of the system, and is calculated according to the following formula:

$$Fr = \frac{1}{2\pi} \sqrt{\frac{K}{m}}$$

Where:

K – stiffness of the motor in Newton/meter

m – mass of the moving part in Kg

If the desired natural frequency is higher than the one calculated for a given configuration, adding another motor in parallel or in tandem increases the system's natural frequency due to the increased stiffness. The combined stiffness of several motors is the algebraic sum of stiffness of the individual motors.

The user should recalculate the natural frequency using the combined stiffness of the motors. It is worthwhile to note that the effective motor stiffness increases under close loop operation.

Driving vertically with a motor that actuates based on friction requires specific consideration to the static load, separate from the dynamic force.

Rule of thumb: each 4N element can drive 120 grams vertically. Beyond this, consider a counter balance in a form of a spring, a continuous force gas spring, or opposing weight.

6.2 Thermal Envelope of Performance (EOP) for HR Motors

6.2.1 Description

Motor operating temperature is a result of the balance between heat generation and heat dissipation.

- The heat generation depends on motor's work regime (driver command level).
- The heat is dissipated through the following heat transfer mechanisms: conduction, radiation and convection (the convection mechanism is negligible in vacuum environment).

The heat dissipation mechanisms should be able to dissipate the heat generated in order to avoid overheating. The EOP gives the user the tools to assess the permitted operating conditions (for set ambient temperature and command, deriving the duty cycle and maximal continuous operation that assures safe operation).

The user can either operate the motor for an extended period of time at a specific duty cycle or alternatively, can operate the motor for a continuous time period specified under “Maximal Continuous Operation Time” (see graphs and tables in sections 6.2.3 and 6.2.4). After the continuous operation is completed, the driver must be disabled to cool down the motor for 400 sec in air and for 700 sec in vacuum environment.

**Notes:**

- *The duty cycle is the ratio of the operation time and the total work cycle (operation time + idle time).*
- *When operating the motor with the AB5/AB51 driver continuously in Brake_Off Mode (refer to section 6.2.4 "EOP for HR Motors Driven by AB5, AB51 Driver"), the motor consumes power at all times, even when the control command voltage is "0" (zero) thus the time at "0" command is accounted in the heating process and reduces the thermal EOP.*
- *Upon operating a motion system in vacuum, it is expected that the Coefficient of Friction of the bearing structure will increase. This may require changing the system operation point on the thermal EOP curves.*

6.2.2 Stage Heat Dissipation Consideration

The motor heat dissipation mechanism is by convection and radiation to the motor case, and by conduction through motor's 'finger tips'. Hence, the motor and the Ceramic Driving Strip bases, must both be thermally designed to dissipate 2W each (per motor's 'finger tip'), with maximum temperature rise of 15°C.

6.2.3 Thermal EOP for HR8 Motor Driven by AB1A, AB2 AB4 Drivers

Figure 6 illustrates motor velocity as a function of the applied driver command voltage. Allowing up to 30 mm/sec variations, use it as a reference and as a guideline for expected motor performance:

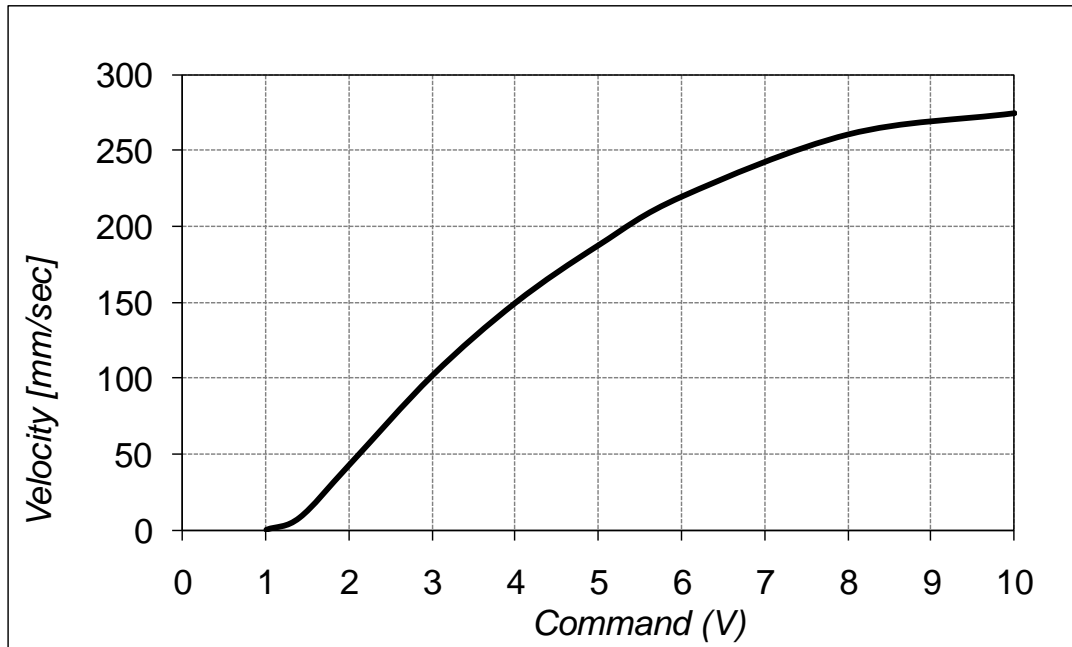

Figure 6: Motor Velocity vs. Command¹

¹ The motor operates horizontally at room temperature and low duty cycle (< 10%). It interfaces with the Ceramic Driving Strip (according to Nanomotion Specifications) and a cross-roller high quality slide.

Figure 7 and Table 1 are designed to help the user determining the correct envelope of performance and avoid overheating and damaging the motor.

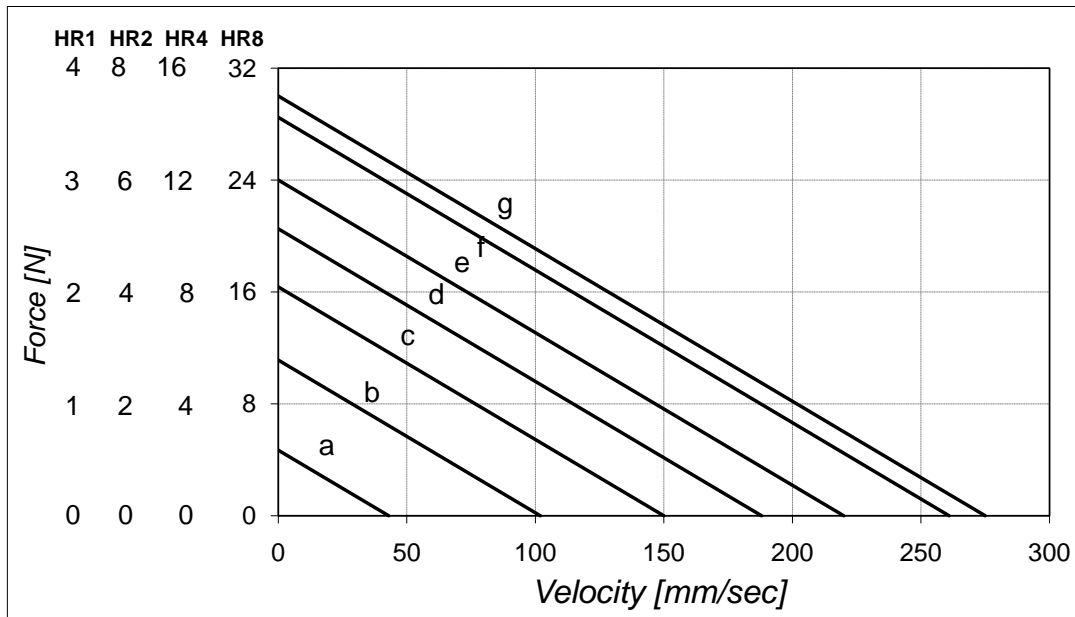

Figure 7: Motor Force vs. Velocity at the Various Work Regimes (a-g)

AB1A, AB2, AB4						
Curve	Air 25°C		Air 50°C		Vacuum	
	Duty Cycle [%]	Maximal Continuous Operation time [sec]	Duty Cycle [%]	Maximal Continuous Operation time [sec]	Duty Cycle [%]	Maximal Continuous Operation time [sec]
a	100	∞	100	∞	100	∞
b	100	∞	100	∞	44	184
c	100	∞	92	137	26	107
d	100	∞	62	93	17	72
e	78	87	47	70	13	55
f	56	62	33	50	9	39
g	50	56	30	45	8	35

Table 1: EOP Table for HR Motors Driven by AB1A, AB2, AB4

6.2.3.1 An Example for Defining the EOP for AB1A Driver in Vacuum Environment

An example for using the graph and table (Figure 7 and Table 1) for the AB1A driver:

A vacuum application requires 10N at a velocity of 100mm/sec. The graph shows that this point of operation corresponds to the curve "d".

The table shows that curve "d" and a vacuum environment require that a duty cycle of 17% will not be exceeded and the maximum continuous operation time is limited to 72 seconds.

6.2.4 EOP for HR Motors Driven by AB5, AB51 Drivers

The AB5, AB51 drivers are preferable for a perfect servo tracking and/or very low ripple constant velocity. Refer to the "AB5 and AB51 Drivers User Manual", D/N: AB05458200. The AB5 unique features result in the motor consuming more power and in a lower EOP, compared to the EOP for a motor operating with the AB1A driver.

The AB51 driver is a modified version of the AB5 driver, which gives a higher EOP, compared to the AB5 driver, with some adverse effect on control performance in respect to tracking error and low velocity ripple.

Figure 8 illustrates motor velocity as a function of the applied AB5/AB51 driver command voltage. Allowing up to 30 mm/sec variations, use it as a reference and as a guideline for expected motor performance:

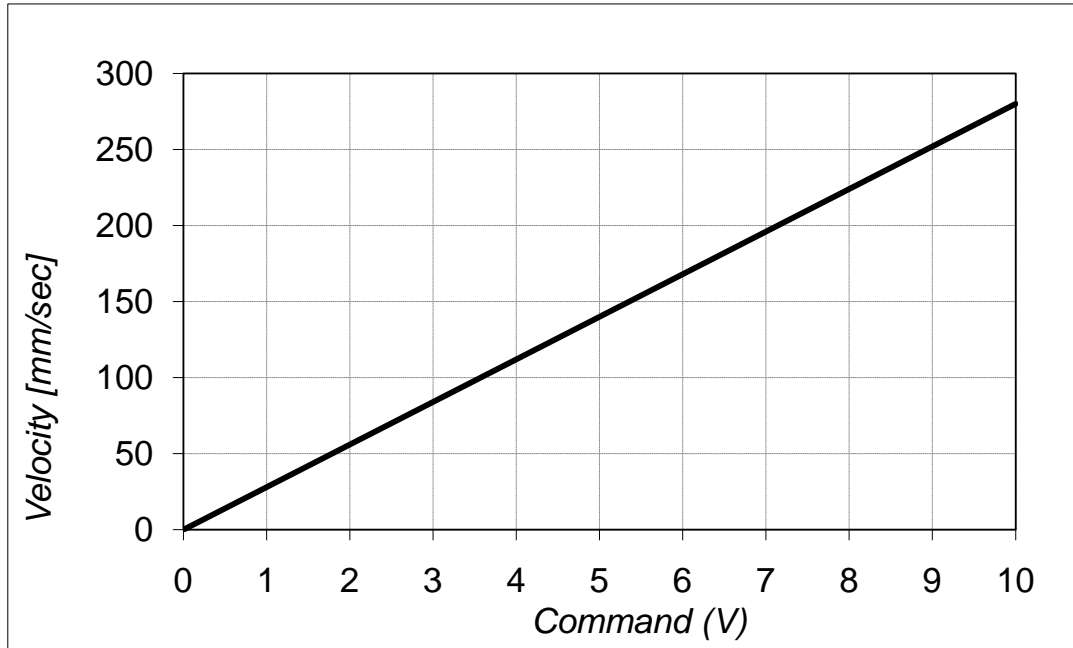

Figure 8: Velocity vs. Command Using the AB5/AB51 Driver

Figure 9 and Table 2 are designed to help the user determining the correct envelope of performance and avoid overheating and damaging the motor.

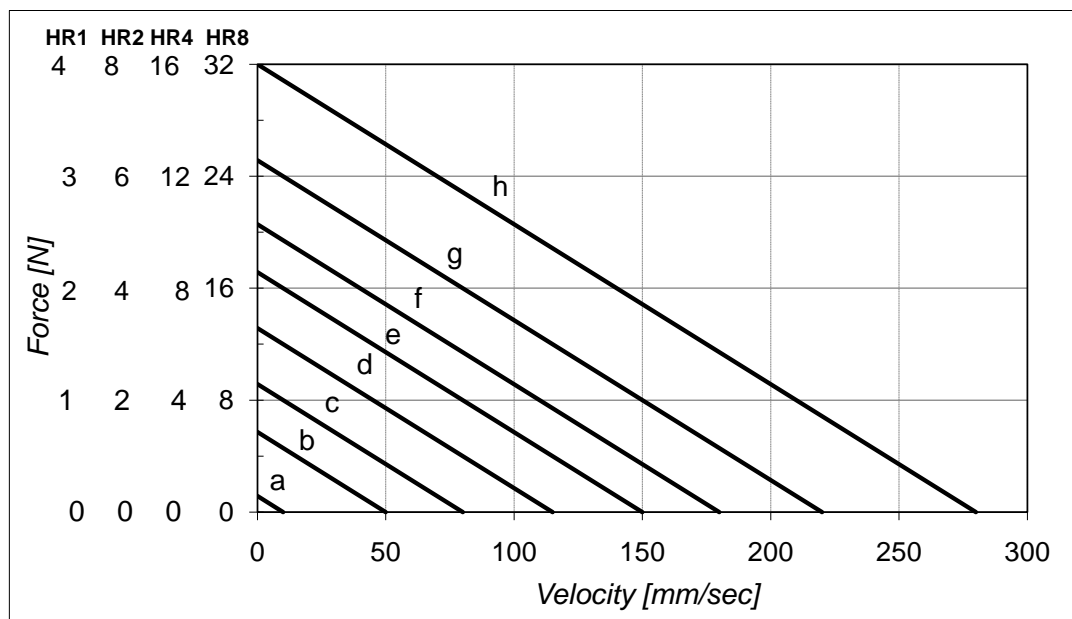

Figure 9: Force vs. Velocity Using the AB5/AB51 Driver at the Various Work Regimes (a-h)

AB5					
Curve	Air 25°C			Vacuum	
	Duty Cycle Brake_Off [%]	Duty Cycle Brake_On [%]	Continues Operation [sec]	Duty Cycle Brake_On [%]	Continues Operation [sec]
“0”÷a	100	100	∞	28	230
b	100	100	∞	23	210
c	100	100	∞	19	150
d	100	100	∞	14	110
e	50	80	280	13	90
f	33	58	170	12	66
g	24	45	77	10	44
h	11	28	32	6.5	25

Table 2: EOP Table for HR Motors Driven by AB5 (Standard LUT)

AB51					
Curve	Air 25°C			Vacuum	
	Duty Cycle Brake_Off [%]	Duty Cycle Brake_On [%]	Continues Operation [sec]	Duty Cycle Brake_On [%]	Continues Operation [sec]
“0”÷a	100	100	∞	56	500
b	100	100	∞	54	450
c	100	100	∞	45	280
d	100	100	∞	33	170
e	100	100	∞	23	100
f	53	58	170	12	66
g	33	48	77	10	44
h	17	28	32	6.5	25

Table 3: EOP Table for HR Motors Driven by the AB51 Driver (Reduced LUT).



Note:

- *In the Brake_Off Mode the full advantage of the AB5 driver is enabled giving a linear response, best tracking and low velocity performance. Using this mode, the motor operates continuously, even at “0” command and special attention must be given to maintain the work regime within the permitted "Duty Cycle" and "Maximal Continuous Operation Time" (refer to Table 2 and Table 3). Once the operation time has reached the "Maximal Continuous Operation Time", even at Brake_Off Mode without motion (!) the driver must be disabled to allow the motor to cool down for at least 400 seconds in air and 700 sec in vacuum environment.*

6.2.4.1 An Example for Defining the EOP for AB5 Driver in Vacuum Environment, Brake_On Mode

A vacuum application requires 8N at a velocity of 80mm/sec and the motor is disabled when stand still (Brake_On Mode). The graph (see Figure 9) shows that this point of operation corresponds to the curve "e" (see Table 2).

Table 2 for AB5 in Brake_On Mode shows that curve "e" and a vacuum environment require that a duty cycle of 13% will not be exceeded and the maximum continuous operation time is limited to 90 seconds. Alternatively AB51 can be used giving duty cycle and continuous operation of 23% and 100 sec respectively.

The same conditions under Air at 25°C will result in 100% Duty Cycle and unlimited continuous operation.

6.2.4.2 An Example for Defining the EOP for AB5 Driver in Vacuum Environment, Brake_Off Mode

When Brake_Off Mode is used under vacuum conditions the motor will overheat at any duty cycle, if operated for a prolong time. To calculate the max operation time, use curve "0÷a" (see Table 2) for time at "0" command and the operation curve for the operating time according to the following formula:

$$T_{\max} = (\text{max continues operation at the operation regime}) * DC + (\text{max continuous operation under regime "a"}) * (1 - DC).$$

If operating under curve "c" (see Table 2), using AB5 in a duty cycle of 10%, the total operation time is:

$$T_{\max} = 150 * 0.1 + 230 * (1 - 0.9) = 222 \text{ sec}$$

Once Tmax is reached, the driver should be disabled for a period of 700 sec.

6.3 Standard Motor Connector Pinout

This section describes the motor connector pinout. Make sure the driver is set to operate with the HR motor series. The motor driver connection is a standard 9 contacts D-type female connector, see Figure 10:

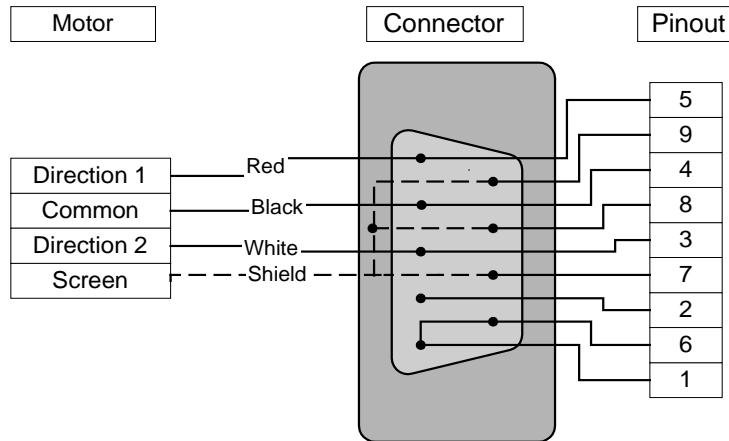

Figure 10: Standard Motor Connector



CAUTION:

- In case the user replaces the original standard motor connector with user's compatible connector, it is essential to short-circuit pins 1 and 6 for safety reasons, refer to Figure 10 and Table 4.

Pin #	Pin Name	Function	Description
1	GND	System ground	Safety input; shorted to pin 6 in order to verify the motor connection and to prevent driver's operation without the motor.
2	N.C.	Not connected	N/A
3	Motor_Up	High voltage output	Connected to the white motor terminal.
4	Motor_Common	High voltage output	Connected to the black motor terminal.
5	Motor_Down	High voltage output	Connected to the red motor terminal.
6	Motor_Connected	Input	Safety input; shorted to pin 1 in order to verify the motor connection and prevent driver's operation without the motor.
7	Shield	Inner shield	Shorted to the shield
8	N.C.	Not connected	N/A
9	N.C.	Not connected	N/A

Table 4: Motor Connector Pinout

6.4 Ultra-High Vacuum Motor Connection Wires

- The HR UHV motor does not have an outlet cable or a connector. Instead it has 3 TFE jacketed flying wire leads, extending out of the motor: black, red and white, see Figure 11. The red and the white wires are directions: down and up respectively, and the black wire is the common.
- The user should provide a UHV compatible cable and connector for connecting the motor.
- **Ensure that pins 1 and 6 of the connector are short-circuited.** Refer to Table 4: Motor Connector Pinout in section 6.3.

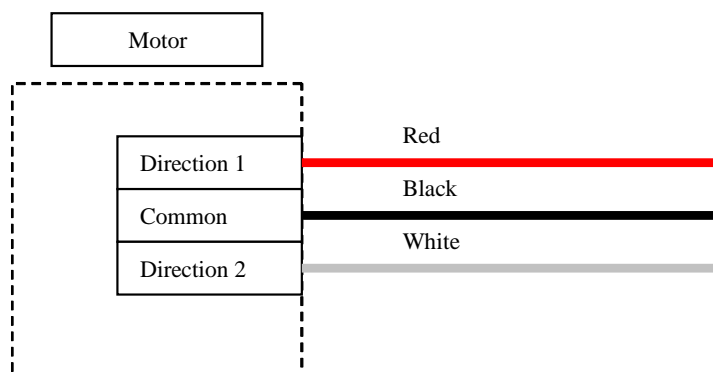

Figure 11: UHV Motor Connection Wires

6.5 A Quad B Encoder Connector Pinout

The encoder connector is a D-Type 15pin, male. This connector is compatible to Renishaw RGH24 digital encoder. Note: this connector pinout is valid aslo for the interpolator output (refer to section 3.3.3 for connecting the interpolator).

Pin #	Pin Name	Function
7, 8	5V	Power
2, 9	0V	
14	A+	Incremental signals
6	A-	
13	B+	
5	B-	
12	Z+/Q-	Reference mark / Index
4	Z-/Q+	
15	Shield	Inner shield
Case		Outer shield
1, 3	N.C.	Not connected
10-11	N.C.	Not connected

Table 5: AqB Encoder Pinout

6.6 Sin/Cos Encoder Connector Pinout

The encoder connector is a D-Type 15pin, male. This connector is compatible to Renishaw RGH24 analogue encoder.

Pin #	Pin Name	Function
4, 5	5V	Power
12, 13	0V	
9	V ₁ +/I ₁ +	Incremental signals
1	V ₁ -/I ₁ -	
10	V ₂ +/I ₂ +	
2	V ₂ -/I ₂ -	
3	V ₀ +/I ₀ +	Reference mark / Index
11	V ₀ -/I ₀ -	
15	Shield	Inner shield
Case		Outer shield

Table 6: Sin/Cos Encoder Pinout

7 Ordering Information

7.1 Part Numbering Scheme

Available configurations for the FB stages:

Product	Width (mm)	-	Travel (mm)	-	Encoder resolution	HR Motor type
FB	050	-	020 050 060 075	-	10M = 1 µm optional 05M = .5 µm optional 01M = 0.1 µm standard 50N = 50 nm optional 10N = 10 nm optional ALG = Sin/Cos optional	2 = HR2 4 = HR4
FB	075	-	040 060 100 150	-	10M = 1 µm optional 05M = .5 µm optional 01M = 0.1 µm standard 50N = 50 nm optional 10N = 10 nm optional ALG = Sin/Cos optional	4 = HR4 8 = HR8
FB	100	-	060 100 150 300	-	10M = 1 µm optional 05M = .5 µm optional 01M = 0.1 µm standard 50N = 50 nm optional 10N = 10 nm optional ALG = Sin/Cos optional	4 = HR4 8 = HR8
FB	150	-	100 150 200 300	-	10M = 1 µm optional 05M = .5 µm optional 01M = 0.1 µm standard 50N = 50 nm optional 10N = 10 nm optional ALG = Sin/Cos optional	4 = HR4 8 = HR8

7.2 Example Configurations

- FB150 stage with 100mm travel, Sin/Cos encoder and HR8 motor:

FB	150	-	100	-	ALG	8
----	-----	---	-----	---	-----	---

- FB050 stage with 20mm travel, -0.1M encoder resolution and HR2 motor:

FB	050	-	020	-	10M	2
----	-----	---	-----	---	-----	---

8 Contact Information

8.1 Customer Service

Contact your local distributor or email Nanomotion Ltd. Technical Support Department at techsupport@nanomotion.com, with detailed problem description.

8.2 General Inquiries and Ordering

- Outside the USA

Nanomotion Ltd. Headquarters

Nanomotion Ltd.

PO Box 223

Yokneam, Israel 20692

Tel: + 972-73-2498065

Fax: +972-73-2498099

Web site: www.nanomotion.com

Email: nano@nanomotion.com

- In the USA

Nanomotion Inc. (US) Headquarters

Nanomotion Inc

1 Comac Loop, Ste. 14B2

Ronkonkoma, NY 11779

Tel: (800)821-6266

Fax: (631)585-1947

Web site: www.nanomotion.com

Email: nanous@nanomotion.com