



A Johnson Electric Company

AB1B-3U Driver

User Manual



D/N: AB1B458000-00 REV: B

August 29, 2012

Nanomotion Ltd. POB 623, Yokneam 20692, Israel

Tel: 972-73-2498000 Fax: 972-73-2498099

Web Site: www.nanomotion.com

E-mail: nano@nanomotion.com

Copyright

This document contains proprietary information of Nanomotion Ltd., and Nanomotion Inc., and may not be reproduced in any form without prior written consent from Nanomotion Ltd. and Nanomotion Inc.

No part of this document may be reproduced, translated, stored in a retrieval system or transmitted in any form and by any means, electronic, mechanical, photographic, photocopying, recording, or otherwise, without the written permission of Nanomotion Ltd.

Information provided in this document is subject to change without notice and does not represent a commitment on the part of Nanomotion Ltd.

Copyright 2009-2012, Yokneam, Israel. All rights reserved.

All products and company names are trademarks or registered trademarks of their respective holders.

Limited Warranty

Nanomotion Ltd. (hereinafter NM) warrants the product (other than software) manufactured by it to be free from defects in material and workmanship for a period of time of one year (except those parts normally considered as consumable/expendable components such as motor conditioning brushes). The warranty commences thirty (30) days from the date of shipment.

NM warrants those parts replaced under warranty for a period equal to the remaining warranty coverage of the original part.

NM's sole and exclusive obligation under this warranty provision shall be to repair, or at its sole option exchange defective products or the relevant part or component, but only if: (i) the Purchaser reports the defect to NM in writing and provides a description of the defective product and complete information about the manner of its discovery within ten (10) days of its discovery; (ii) NM has the opportunity to investigate the reported defect and to determine that the defect arises from faulty material, parts or workmanship; and (iii) the Purchaser returns the affected product to a location designated by NM. These provisions constitute the exclusive remedy of the Purchaser for product defects or any other claim of liability in connection with the purchase or use of NM products.

This warranty policy applies only to NM products purchased directly from NM or from an authorized NM distributor or representative.

This warranty shall not apply to (i) products repaired or altered by anyone other than those authorized by NM; (ii) products subjected to negligence, accidents or damage by circumstances beyond NM control; (iii) product subjected to improper operation or maintenance (i.e. operation not in accordance with NM Installation Manuals and/or instructions) or for use other than the original purpose for which the product was designed to be used.

NM shall not in any event have obligations or liabilities to the Purchaser or any other party for loss of profits, loss of use or incidental, increased cost of operation or delays in operation, special or consequential damages, whether based on contract, tort (including negligence), strict liability, or any other theory or form of action, even if NM has been advised of the possibility thereof, arising out of or in connection with the manufacture, sale, delivery, use, repair or performance of the NM products. Without limiting the generality of the preceding sentence, NM shall not be liable to the Purchaser for personal injury or property damages.

Patent Information

Nanomotion products are covered under one or more of the following registered or applied for patents.

5,453,653; 5,616,980; 5,714,833; 111597; 5,640,063; 6,247,338; 6,244,076; 6,747,391; 6,661,153; 69838991.3; 6,384,515; 7,119,477; 7,075,211; 69932359.5; 1186063; 7,211,929; 69941195.5; 1577961; 4813708; 6,879,085; 6,979,936; 7,439,652; 7061158 ;1800356; 1800356; 1800356; 2007-533057 (pending); 2011-093431 (pending); 7,876,509; 10-2007-7009928 (pending); 200780019448.6 ; 7713361.9 (pending); 12/294,926 (pending); GB200800004178 (pending); GB200900003796 (pending); 12/398,216 (pending); GB2446428; 12/517,261 (pending); 08702695.1 (pending); 10-2009-7017629 (pending); 12/524,164 (pending); 12/581,194 (pending)

Revision History

Revision	Release date	Details
00/A	Dec 2009	New Release
00/B	Dec. 2011	Update the EOP chapter
NA	Aug. 2012	Administrative change – added patent information section in front matter.

DRAFT

This page is intentionally left blank.

Table of Contents

1 INTRODUCTION.....	9
1.1 General.....	9
1.2 Main Features.....	10
1.3 Available Configurations	11
1.4 Configuration Examples.....	12
1.4.1 A Six (6) Elements Configuration.....	12
1.4.2 A 32 Elements Configuration	12
1.5 AB1B-3U Operating Principle.....	13
1.5.1 General	13
1.5.2 Driver's Operation Principle	13
2 CONNECTING THE AB1B-3U DRIVER.....	14
2.1 Wires and Connectors	14
2.2 Motor Cable Connections.....	14
2.3 Before Operating the Motor.....	15
3 AB1B-3U OPERATING.....	16
3.1 Operation Modes	16
3.1.1 Velocity Mode Operation	16
3.1.2 Step Mode Operation	17
3.1.3 Gate Mode	17
4 TECHNICAL DATA.....	18
4.1 Specifications.....	18
4.2 Thermal Envelope of Performance (EOP).....	19
4.2.1 Description	19
4.2.2 Stage Heat Dissipation Consideration	20
4.3 Thermal EOP for HR Motors Driven by the AB1B-3U Driver	20

4.3.1 An Example for Defining the EOP for AB1B-3U Driver in Vacuum Environment 22

4.4 Front Panel LED Indicators 23

 4.4.1 Front Panel Description 23

 4.4.2 LED Indicators..... 23

4.5 Mother Board (MB) Interface Connector 24

 4.5.1 MB Interface Connector Pinout..... 24

 4.5.2 MB Interface Connector Pinout (Cont.)..... 25

 4.5.3 Opto-isolated Inputs 26

 4.5.4 Voltage Source Configuration..... 27

 4.5.5 Fault Output 28

4.6 AB1B-3U Mechanical Layout 29

4.7 Mechanical Enclosure Design..... 29

5 PART NUMBERING METHODOLOGY..... 30

6 CONTACT INFORMATION..... 31

 6.1 Nanomotion Ltd. Headquarters 31

 6.2 Nanomotion Inc. (US) Headquarters 31

List of Figures

Figure 1: AB1B-3U Driver	9
Figure 2: Block Diagram of a Typical Application of the AB1B-3U Driver.....	13
Figure 3: Motor Velocity vs. Command	20
Figure 4: Motor Force vs. Velocity at the Various Work Regimes (a-g)	21
Figure 5: AB1B-3U Front Panel.....	23
Figure 6: Opto-Isolated Input Interface.....	26
Figure 7: JP1 Configuration.....	27
Figure 8: Layout and Mechanical Dimensions	29

List of Tables

Table 1: AB1B Configurations, Using HR Motor Types	11
Table 2: A Six (6) Elements Configuration.....	12
Table 3: A 32 Elements Configuration.....	12
Table 4: AB1B-3U Driver Specifications.....	18
Table 5: EOP Table for HR Motors Driven by AB1B-3U Driver.....	21
Table 6 : Front Panel LED Indicators	23
Table 7: MB Interface Connector Pinout (Cont.).....	25

1 Introduction

This manual is designed to help the reader to operate the AB1B-3U driver. It assumes that the reader has a fundamental understanding of basic servo systems, as well as motion control concepts and applicable safety procedures.

1.1 General

The AB1B-3U driver is a single-axis card level amplifier for driving Nanomotion Piezo-Ceramic motors. The AB1B-3U driver interfaces between the input command from a controller to the motor and drives the Piezo motor. The AB1B-3U driver is designed to drive up to 48 Nanomotion HR motor elements in parallel in 3 channels of up to 16 elements.

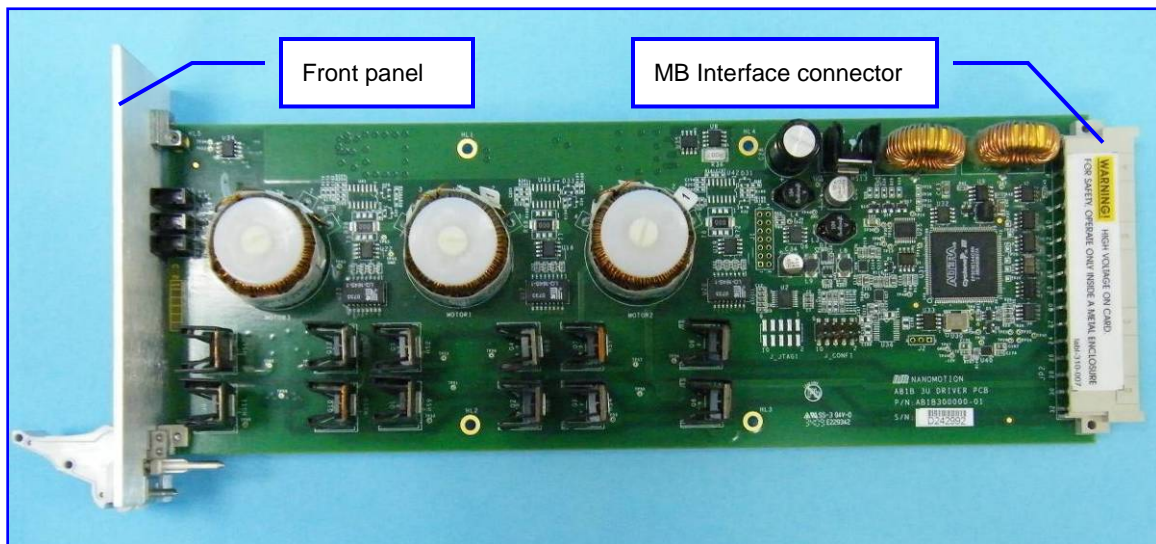

Figure 1: AB1B-3U Driver

The AB1B-3U driver includes of an integrated LC circuit, front panel with LED indicators and a Mother Board (MB) Interface connector (see section 4.5.2 and section 4.4.2 for details).

1.2 Main Features

- High precision (11 bits) control of the power output stage
- Drives up to 48 HR motor elements in 3 channels of up to 16 elements in parallel
- Interface with an Analog command
- Discrete inputs enable feedback from external sources, such as emergency stop command, etc.
- LED indicators
- Output short circuit protection

1.3 Available Configurations

The AB1B driver card has three (3) output channels (CH). The configurations described in Table 1 must follow the conditions below:

- CH1 must always be connected.
- CH2 and CH3 are optional.
- CH2 and/or CH3, if connected, must have the same motor type as CH1.
- For configurations, having more than one identical motors connected **per channel**, use suitable branch cable, see section 2.2 for more details.

Channel	Configurations			
	Up to 24 Elements (no branch cable)			32 or 48 Elements(with branch cable)
CH1	HR1 HR2 HR4 HR8	HR1 HR2 HR4 HR8	HR1 HR2 HR4 HR8	2xHR8
CH2	-	HR1 HR2 HR4 HR8	HR1 HR2 HR4 HR8	2xHR8
CH3	-	-	HR1 HR2 HR4 HR8	2xHR8

Table 1: AB1B Configurations, Using HR Motor Types

1.4 Configuration Examples

1.4.1 A Six (6) Elements Configuration

Table 2 shows a six (6) elements configuration, using 3xHR2 motors:

Channel	Up to 24 Elements (no branch cable)			32 or 48 Elements(with branch cable)
CH1	HR2	-	-	-
CH2	HR2	-	-	-
CH3	HR2	-	-	-

Table 2: A Six (6) Elements Configuration

1.4.2 A 32 Elements Configuration

Table 3 shows a 32 elements configuration, using 4xHR8 motors, connected by branch cables:

Channel	Up to 24 Elements (no branch cable)			32 or 48 Elements(with branch cable)
CH1	-	-	-	2xHR8
CH2	-	-	-	2xHR8
CH3	-	-	-	-

Table 3: A 32 Elements Configuration.

1.5 AB1B-3U Operating Principle

1.5.1 General

The force transfer of the Nanomotion motor is based on friction of the motor's elements and the drive strip. This drive mechanism has many advantages, like high precision, zero backlash, inherent brake and more.

1.5.2 Driver's Operation Principle

The AB1B-3U driver converts the analog input command signal into a corresponding PWM square wave output signal. The PWM signal is fed into the integrated LC circuit. The LC circuit outputs a sine wave voltage that drives the motor. Figure 2 illustrates a typical application of the AB1B-3U Driver.

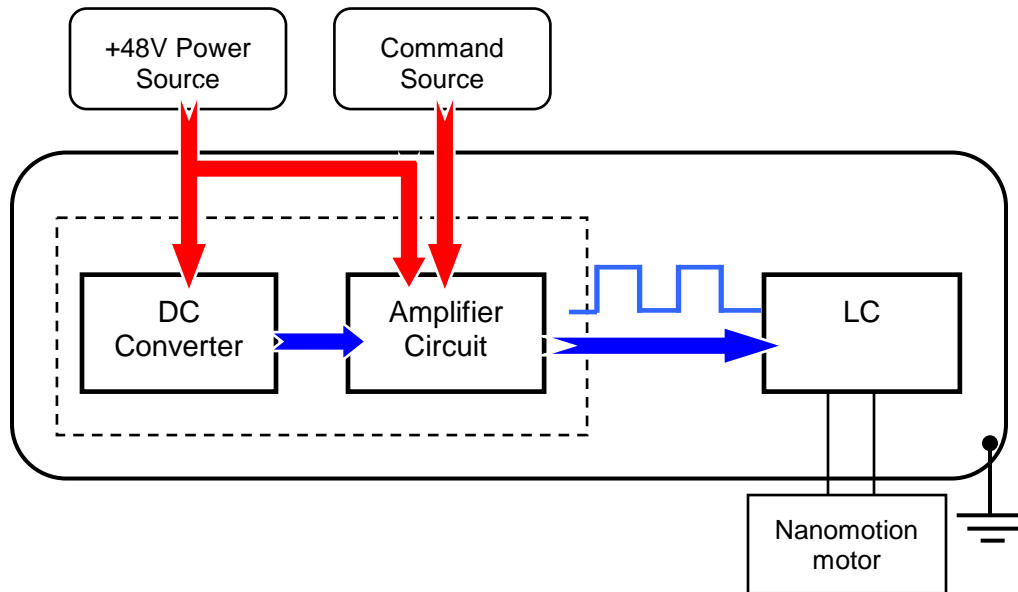

Figure 2: Block Diagram of a Typical Application of the AB1B-3U Driver

Note:

- ▣ The LC circuit type and configuration should be according to the number of motor elements driven.

2 Connecting the AB1B-3U Driver



WARNING!

To prevent minor electric shock hazard, the driver must be grounded to infrastructure earth.

2.1 Wires and Connectors

- **Power supply:** use 22 AWG (or lower AWG) wires for the power supply. For noisy surroundings, it is recommended to twist the ground line and the power line together.
- **Analog command:** a twisted shielded cable is recommended.
- **Discrete inputs:** these signals are not sensitive to noise and can be grouped together in the same harness.

2.2 Motor Cable Connections

Nanomotion guarantees proper driver and motor performance only when Nanomotion standard cables are used.

- The Motor_Connected_In interlock is available at the motor connector, (refer to Nanomotion motor user manual). It disables high voltage on the bare driver output connector, when the motor is not connected.
- The allowed maximum total motor cable length (connecting the AB1B-3U driver to the motor/s) is up to 10 meters for the HR motor.
- Use a suitable branch cable if more than two identical motors are connected to a channel (CH). The available branching cables are for motors operating either side by side (P/N: MIC-2-U) or head to head (P/N: MIC-2-R). Branch cables must be of identical length. Their total length should not exceed the allowed total cable length.

2.3 Before Operating the Motor

Before operating the AB1B-3U, verify the following:

- The motor type matches the driver configuration.
- All motors are properly mounted and preloaded.
- Jumper JP1 is set to the required mode of operation (see section 4.5.4 for more details).
- The external power supply is capable of supplying the required power consumption of the AB1B-3U driver.
- There is no command from the Controller.

3 AB1B-3U Operating

CAUTION:

The command should be limited according to the motor Envelope of Performance (see to section Error! Reference source not found. for more details).

3.1 Operation Modes

The AB1B-3U driver can be operated in one of the three operation modes listed below:

- **Velocity (AC) Mode:** the motor is driven continuously.
- **Step Mode:** the driver output, defined in the hardware, turned OFF and ON, in predefined intervals of 1/16 sec every 1/2 sec, thus driving the motor in discrete steps.
- **Gate Mode:** the motor is driven at low velocity by turning the driver output ON and OFF in time intervals defined by outside TTL signal in an open loop.

3.1.1 Velocity Mode Operation

In this operation mode, the motor is driven continuously by applying the analog command voltage (± 10 V), using a relevant interface device.

This mode is driver's default operation mode.

3.1.2 Step Mode Operation

In this operation mode, the driver output to the motor is turned ON and OFF for fixed time intervals defined in the hardware, as follows:

- ON phase - 1/16 second
- OFF phase - 0.5 second

The amplitude of the output corresponds to the analog command input value and thus determines the speed of the motor.

To enable the Step Mode: short pin B10 (of the MB Interface connector) to ground (see section 4.5, Table 7).

3.1.3 Gate Mode

In this operation mode the motor is driven in open loop at low velocities by turning the driver output ON and OFF in time intervals defined by an external switching.

The amplitude of the output corresponds to the analog input value and thus determines the speed of the motor.

In Gate Mode, as opposed to Step Mode, the pulse width and pulse frequency are user-defined.

The allowable parameter values for the external signal are as follows:

- Voltage level: 0V (ON); 5V (OFF). The open collector logic can be used as an option.
- Minimum pulse width: 50 μ sec.
- Maximum pulse frequency: 1 kHz.

To enable the Gate Mode: short pin Z14 to ground. Verify that pin B10 is not shorted to ground at the same time. Conduct now the external switching signal through pin B10 (see and section 4.5, Table 7).

4 Technical Data

4.1 Specifications

Electrical Specifications		
Power Input	+ 48 Vdc \pm 5% (stabilized)	
Current Consumption w/o Load	64 mA @ 48 Vdc	
Power Consumption w/o Load	3.5W	
Recommended Power Supplies		
Supply Voltage	Maximum Current Consumption	Applicable For
+48 Vdc \pm 5%	\leq 600mA	E4
	\leq 2.2A	E16
	\leq 7A	E48
Physical Properties		
Weight	450g	
Environmental Conditions		
Enclosure Ambient Temperature	0°C to 45°C	
Storage Temperature	- 40°C to 70°C	
Analog Input Specifications		
Input voltage range	\pm 10V	
Input impedance	10k Ω	
Input low pass filter	2.7 kHz	

Table 4: AB1B-3U Driver Specifications

4.2 Thermal Envelope of Performance (EOP)

4.2.1 Description

Motor operating temperature is a result of the balance between heat generation and heat dissipation.

- The heat generation depends on motor's work regime (driver command level).
- The heat is dissipated through the following heat transfer mechanisms: conduction, radiation and convection (the convection mechanism is negligible in vacuum environment).

The heat dissipation mechanisms should be able to dissipate the heat generated in order to avoid overheating. The EOP gives the user the tools to assess the permitted operating conditions (for set ambient temperature and command, deriving the duty cycle and maximal continuous operation that assures safe operation).

The user can either operate the motor for an extended period of time at a specific duty cycle or alternatively, can operate the motor for a continuous time period specified under "Maximal Continuous Operation Time" (see graph and table in section 4.3). After the continuous operation is completed, the driver must be disabled to cool down the motor for 400 sec in air and for 700 sec in vacuum environment.



Notes:

- ▣ *The duty cycle is the ratio of the operation time and the total work cycle (operation time + idle time).*
- ▣ *Upon operating a motion system in vacuum, it is expected that the Coefficient of Friction of the bearing structure will increase. This may require changing the system operation point on the thermal EOP curves.*

4.2.2 Stage Heat Dissipation Consideration

The motor heat dissipation mechanism is by convection and radiation to the motor case, and by conduction through motor's 'finger tips'. Hence, the motor and the Ceramic Driving Strip bases, must both be thermally designed to dissipate 2W each (per motor's 'finger tip'), with maximum temperature rise of 15°C.

4.3 Thermal EOP for HR Motors Driven by the AB1B-3U Driver

Figure 3 illustrates motor velocity as a function of the applied driver command voltage. Allowing up to 30 mm/sec variations, use it as a reference and as a guideline for expected motor performance:

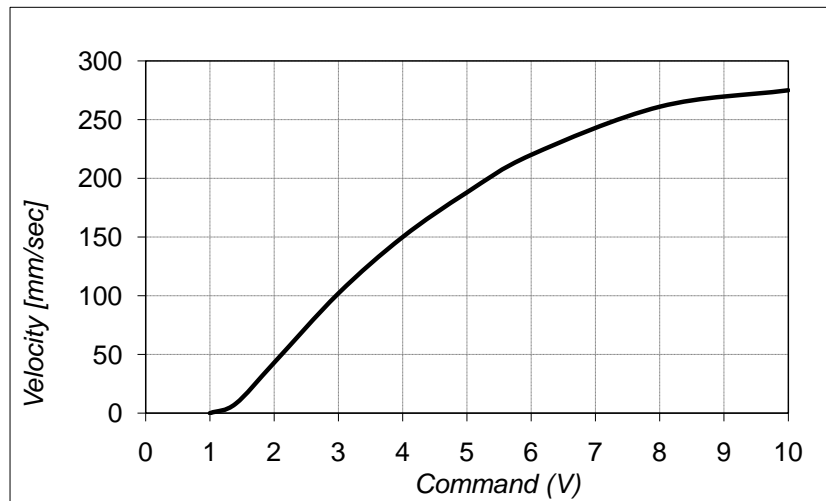

Figure 3: Motor Velocity vs. Command¹

Figure 4 and Table 5 are designed to help the user determining the correct envelope of performance and avoid overheating and damaging the motor.

¹ The motor operates horizontally at room temperature and low duty cycle (< 10%). It interfaces with the Ceramic Driving Strip (according to Nanomotion Specifications) and a cross-roller high quality

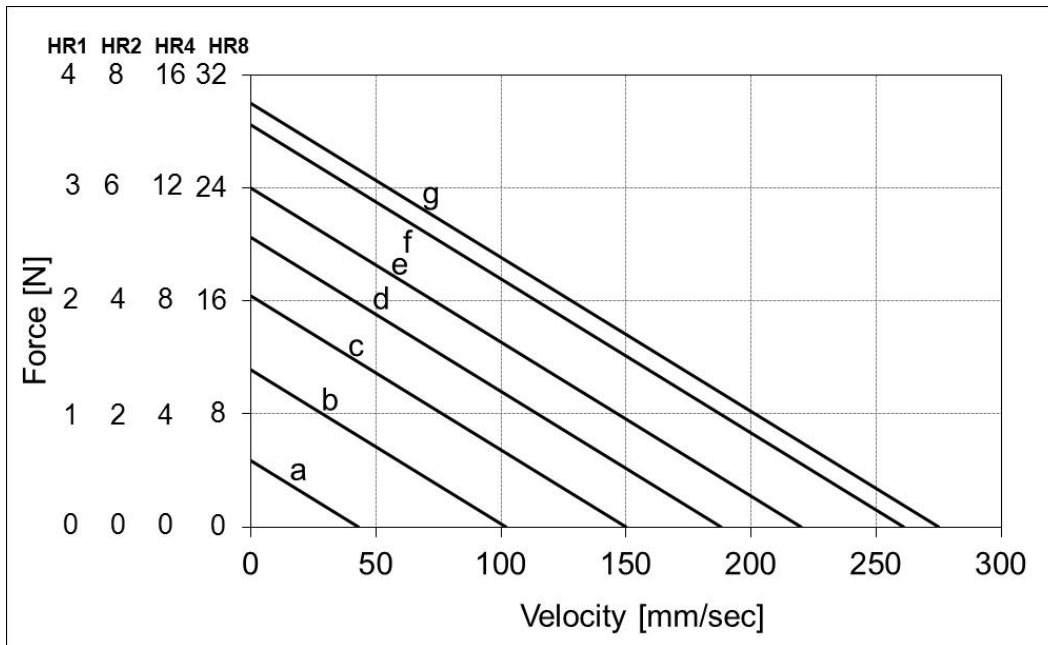

Figure 4: Motor Force vs. Velocity at the Various Work Regimes (a-g)

AB1B-3U						
Curve	Air 25°C		Air 50°C		Vacuum	
	Duty Cycle [%]	Maximal Continuous Operation time [sec]	Duty Cycle [%]	Maximal Continuous Operation time [sec]	Duty Cycle [%]	Maximal Continuous Operation time [sec]
a	100	∞	100	∞	100	∞
b	100	∞	100	∞	44	184
c	100	∞	92	137	26	107
d	100	∞	62	93	17	72
e	78	87	47	70	13	55
f	56	62	33	50	9	39
g	50	56	30	45	8	35

Table 5: EOP Table for HR Motors Driven by AB1B-3U Driver

4.3.1 An Example for Defining the EOP for AB1B-3U Driver in Vacuum Environment

An example for using the graph and table (Figure 4 and Table 5) for the AB1B-3U driver and HR8 motor:

A vacuum application requires 10N at a velocity of 100mm/sec. The graph shows that this point of operation corresponds to the curve “d”. The table shows that curve “d” and a vacuum environment require that a duty cycle of 17% will not be exceeded and the maximum continuous operation time is limited to 72 seconds.

4.4 Front Panel LED Indicators

4.4.1 Front Panel Description

The AB1B-3U front panel has the following LED indicators:

- Fault (Red)
- Enable (Yellow)
- Power (Green)



Figure 5: AB1B-3U Front Panel

4.4.2 LED Indicators

Condition	LED Indicator		
	Red	Yellow	Green
48V power supply not connected	OFF	OFF	OFF
48V power supply is connected	OFF	OFF	ON
Motor Connected and Disabled	OFF	OFF	ON
Motor Enabled	OFF	OFF	ON
Over voltage	ON	ON	ON
Over current	ON	ON	ON
Motor disconnected	ON	OFF	ON

Table 6 : Front Panel LED Indicators

4.5 Mother Board (MB) Interface Connector

MB Interface connector: ERNI P/N :334-203

4.5.1 MB Interface Connector Pinout

Pin	Name	Function	Description
B10	Step/Gate Mode	Input	See section 3.1 for Operation Modes.
Z10	Enable_In	Input	Drive enable
D12	Emergency stop	Input	Safety input
Z16, B16, B6, Z18, D20, B20, Z20	N.C.	N/A	N/A
D16	Motor_Connected_In	N/A	Safety input. The motor operation is enabled only when this input is shorted to the ground
Z14	Gate_En	Input	Gate mode enable
B12	Fault	Output	Fault indication (Open collector output)
D18	Vin_Neg	Input	Negative analog command input (0 to -10V)
B18	Vin_Pos	Input	Positive analog command input (0 to +10V)
Z22, Z24	Motor Black 1	Output	Connected to the motor (black wire 1)
B24, D24	Motor White 1	Output	Connected to the motor (white wire 1)
B22, D22	Motor Red 1	Output	Connected to the motor (red wire 1)
D8, B8, Z8	+48V	Input	Power supply
D10	User voltage	Input	3.3V to 5V external supply

Table 4: MB Interface Connector Pinout

4.5.2 MB Interface Connector Pinout (Cont.)

D2	-10V	Output	To joystick
D6	+10V	Output	To joystick
Z2	Fault Code 2	Output	Represents the fault code (open collector)
B2	Fault Code 1	Output	Represents the fault code (open collector)
D4, B4, Z4	GND	N/A	Ground
Z6	Fault Code 0	Output	Represents the fault code (open collector)
Z12	Reset	Input	System initialization. Activated when shorted to ground.
D14	UHR	Input	Future use.
Z26, Z28	Motor Black 2	Output	Connected to the motor (black wire 2)
D28, B28	Motor White 2	Output	Connected to the motor (white wire 2)
D26, B26	Motor Red 2	Output	Connected to the motor (red wire 2)
D32, B32	Motor White 3	Output	Connected to the motor (white wire 3)
B30, D30	Motor Red 3	Output	Connected to the motor (red wire 3)
Z30, Z32	Motor Black 3	Output	Connected to the motor (black wire 3)
B14	OPC_In	Output	General Purpose isolated input

Table 7: MB Interface Connector Pinout (Cont.)

4.5.3 Opto-isolated Inputs

The following inputs are opto-isolated and are active “low”, i.e. by shorting them to ground (see Table 7 for more details):

- **Emergency Stop:** disables driver’s output.
- **Enable:** enables driver operation; should be activated before operating the motor.
- **Step Mode:** enables Step mode operation
- **Gate Mode:** enables Gate mode operation
- **Fault Code 0:** represents fault code (open collector)
- **Fault Code 1:** represents fault code (open collector)
- **Fault Code 2:** represents fault code (open collector)
- **Reset:** enables system initialization. Activated short to ground

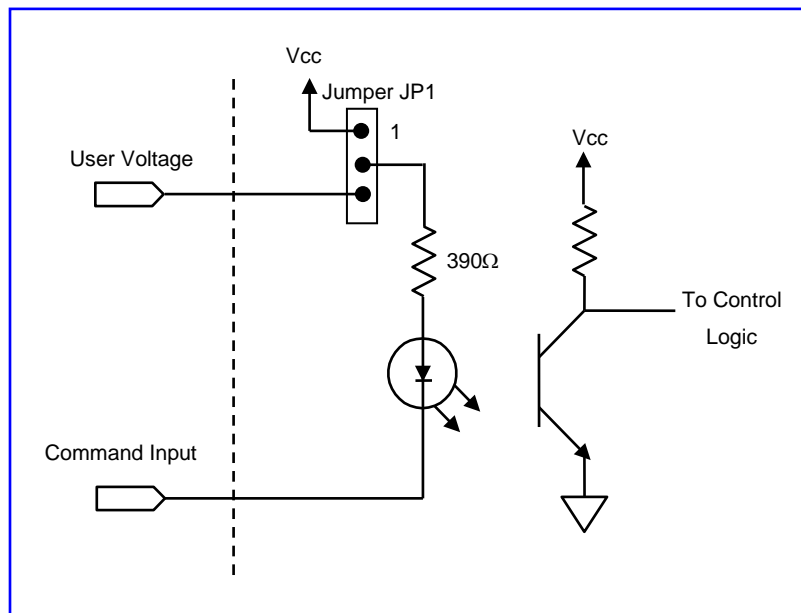

Figure 6: Opto-Isolated Input Interface

4.5.4 Voltage Source Configuration

The opto-isolated input signals (see section 4.5.3) are activated as short-to-ground. The voltage for the opto-isolated circuit (see Figure 6) is provided by either internal +3.3V supply (default state) or an external voltage supply via pin 13 of the I/O Port connector. The input to be activated should be shorted to the external voltage supply ground.

Configure jumper JP1 on the top AB1B-3U card according to the voltage source:

- Pin 1 shorted to Pin 2, for an internal +3.3V source (default factory setting).
- Pin 3 shorted to Pin 4, for an external voltage source from +3.3V to +5V.

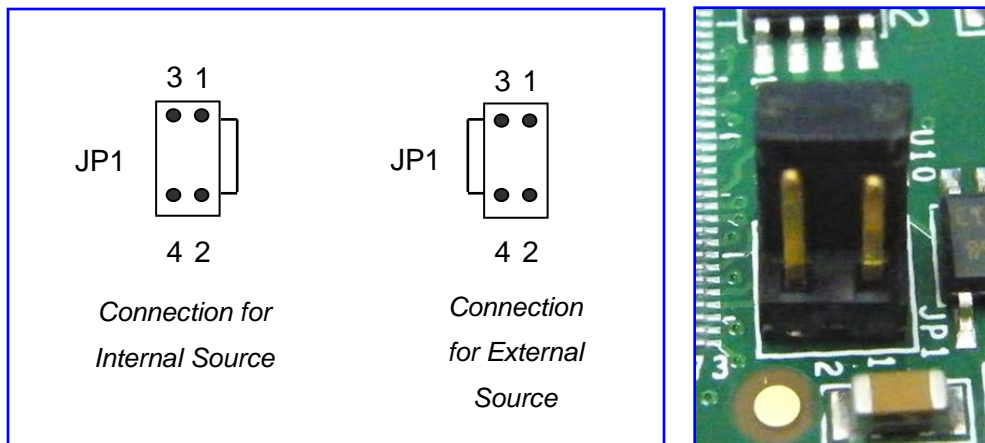

Figure 7: JP1 Configuration

4.5.5 Fault Output

The Fault output indicates either driver's over voltage/current or motor disconnected. When active "low", it disables the driver due to this fault.

The fault output provides an open collector interface and needs to be pulled up by the user.

The maximum allowed current through the open collector transistor is **50mA**. The appropriate pull-up resistors should be used to avoid overloading this output.

4.6 AB1B-3U Mechanical Layout

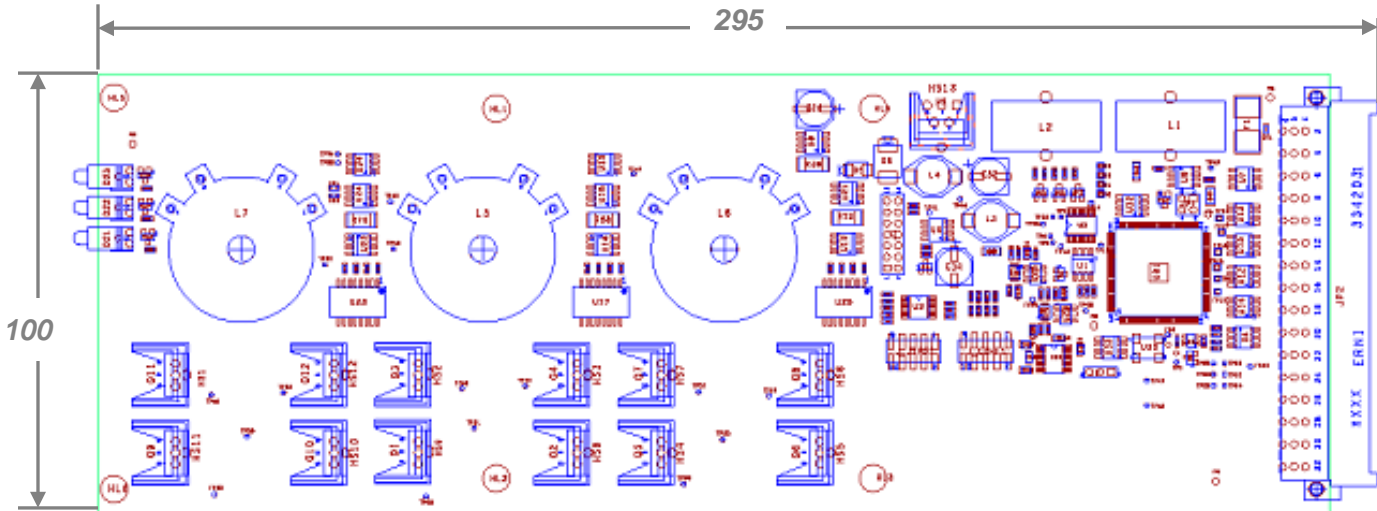

Figure 8: Layout and Mechanical Dimensions

Note:

- All dimensions are in mm

4.7 Mechanical Enclosure Design

In order to design an enclosure box, please consider the following key points:

- The AB1B driver card has standard 3U dimensions (refer to section 4.6). In order to accommodate the driver card, the user should provide a standard 3U enclosure and multiple-access Mother Board (MB).
- Make sure, the spacing between the slots on the MB is 2".
- Nanomotion recommends using Schroff's enclosure or equivalent, which supports the AB1B front panel mechanical interface.
- The 3U enclosure design should adhere to safety considerations, including ventilation and grounding.

5 Part Numbering Methodology

The part numbers for the AB1B-3U drivers follow this methodology:

Driver	Motor Type	Number of Elements
AB1B-3U	HR	EXX

Note:

- “XX” represents number of motor elements, ranging from 1 to 48.

6 Contact Information

6.1 Nanomotion Ltd. Headquarters

Nanomotion Ltd.

PO Box 223

Yokneam, Israel 20692.

Tel: +972-73-2498000

Fax: +972-73-2498099

Web site: www.nanomotion.com

Email: nano@nanomotion.com

6.2 Nanomotion Inc. (US) Headquarters

Nanomotion Inc

1 Comac Loop, Ste. 14B2

Ronkonkoma, NY 11779

Tel: (800)821-6266

Fax: (631)585-1947

Web site: www.nanomotion.com

Email: nanous@nanomotion.com