



A Johnson Electric Company

ST Motor User Manual

D/N: MST1458000-00 REV: C

December 2008

Nanomotion Ltd. POB 623, Yokneam 20692, Israel

Tel: 972-73-2498000 Fax: 972-73-2498099

Web Site: www.nanomotion.com

E-mail: nano@nanomotion.com

CE Compliance

This product has been tested for Electromagnetic compatibility and found to be in compliance with:

EMC: Directive 89/336/EEC as amended by 92/31/EEC and 93/68/EEC

Harmonized Standards to which conformity is declared:

EN 50081-2:1993/EN 55011:1991

Generic Emission Standards Class A for radiated emission and Class B for conducted emission.

EN 50082- 2:1995

Generic Immunity Standard

Copyright

This document contains proprietary information of Nanomotion Ltd., and Nanomotion Inc., and may not be reproduced in any form without prior written consent from Nanomotion Ltd. and Nanomotion Inc.

No part of this document may be reproduced, translated, stored in a retrieval system or transmitted in any form and by any means, electronic, mechanical, photographic, photocopying, recording, or otherwise, without the written permission of Nanomotion Ltd.

Information provided in this document is subject to change without notice and does not represent a commitment on the part of Nanomotion Ltd.

Copyright February 2004, Yokneam, Israel. All rights reserved.

All products and company names are trademarks or registered trademarks of their respective holders.

Limited Warranty

Nanomotion Ltd. (hereinafter NM) warrants the product (other than software) manufactured by it to be free from defects in material and workmanship for a period of time of one year (except those parts normally considered as consumable/expendable components such as motor conditioning brushes). The warranty commences thirty (30) days from the date of shipment.

NM warrants those parts replaced under warranty for a period equal to the remaining warranty coverage of the original part.

NM's sole and exclusive obligation under this warranty provision shall be to repair, or at its sole option exchange defective products or the relevant part or component, but only if: (i) the Purchaser reports the defect to NM in writing and provides a description of the defective product and complete information about the manner of its discovery within ten (10) days of its discovery; (ii) NM has the opportunity to investigate the reported defect and to determine that the defect arises from faulty material, parts or workmanship; and (iii) the Purchaser returns the affected product to a location designated by NM. These provisions constitute the exclusive remedy of the Purchaser for product defects or any other claim of liability in connection with the purchase or use of NM products.

This warranty policy applies only to NM products purchased directly from NM or from an authorized NM distributor or representative.

This warranty shall not apply to (i) products repaired or altered by anyone other than those authorized by NM; (ii) products subjected to negligence, accidents or damage by circumstances beyond NM control; (iii) product subjected to improper operation or maintenance (i.e. operation not in accordance with NM Installation Manuals and/or instructions) or for use other than the original purpose for which the product was designed to be used.

NM shall not in any event have obligations or liabilities to the Purchaser or any other party for loss of profits, loss of use or incidental, increased cost of operation or delays in operation, special or consequential damages, whether based on contract, tort (including negligence), strict liability, or any other theory or form of action, even if NM has been advised of the possibility thereof, arising out of or in connection with the manufacture, sale, delivery, use, repair or performance of the NM products. Without limiting the generality of the preceding sentence, NM shall not be liable to the Purchaser for personal injury or property damages.

Table of Contents

1 INTRODUCTION.....	7
1.1 Handling and Safety Precautions	7
2 MOTOR INSTALLATION.....	8
2.1 Mounting the motor.....	8
2.2 Motor Grounding.....	8
2.3 Motor Connections	9
3 MOTOR CONDITIONING	10
4 TECHNICAL DATA.....	11
4.1 Specifications	11
5 ENVELOP OF PERFORMANCE (EOP).....	12
5.1 Defining the EOP	15
5.2 Considerations for Heat Dissipation in Vacuum Environment	15
6 DIMENSIONS.....	16

List of Figures

Figure 1: Mounting the motor.....	8
Figure 2: Driver Connector Pin Arrangement.....	9
Figure 3: Motor Velocity vs. Command.....	12
Figure 4: Force vs. Velocity at Various Work Regimes.....	13

List of Tables

Table 1: EOP	13
--------------------	----

List of Abbreviations

A	Ampere
AC	Alternating Current
DC	Direct Current
LED	Light Emitting Diode
mA	milli Ampere
mW	milli Watt
PWM	Pulse Width Modulation
TTL	Transistor-Transistor Logic
Vrms	Volts Root Mean Square
DIP	Dual-In-line Package

1 Introduction

This manual is designed to help the reader to operate the ST Motor. It assumes that the reader has a fundamental understanding of basic servo systems, as well as motion control concepts and applicable safety procedures.

1.1 Handling and Safety Precautions

Do not power on the motor unless it is properly mounted as explained. Use only a clean cloth to wipe the motor. Do not use any solvents.

Ensure that the motor and specifically its tip are not subjected to mechanical shocks.

The mounting base and the method used for mounting should be designed for maximum mechanical rigidity and stiffness.

2 Motor Installation

2.1 Mounting the motor

Mount the Motor on the Base plate as shown in Figure 1. Use the spacer to ensure the correct distance between the motor and the ceramic drive strip.

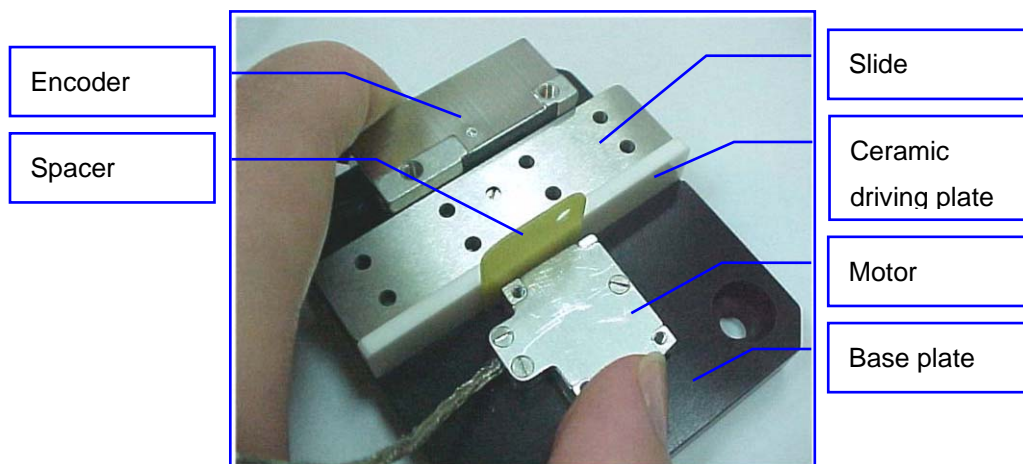

Figure 1: Mounting the motor

Use 4XM2 screws to tighten motor to base.

2.2 Motor Grounding

Be sure to ground the motor (or its conductive base plate) to the electrical network ground, before operating.

2.3 Motor Connections

This section describes the Motor connector Pin Out and the connections to each of the available drivers. Ensure that the driver is set to operate with the ST motor series.

IMPORTANT!

Reducing the length of the supplied motor cable may damage the motor. Do not attempt to shorten the cable without prior confirmation by Nanomotion.

Extending the motor cable will not damage the motor, however it will affect its performance.

The Motor Driver connection uses a standard 9-pin D-type female connector. For the pin arrangement diagram, refer to Figure 2.

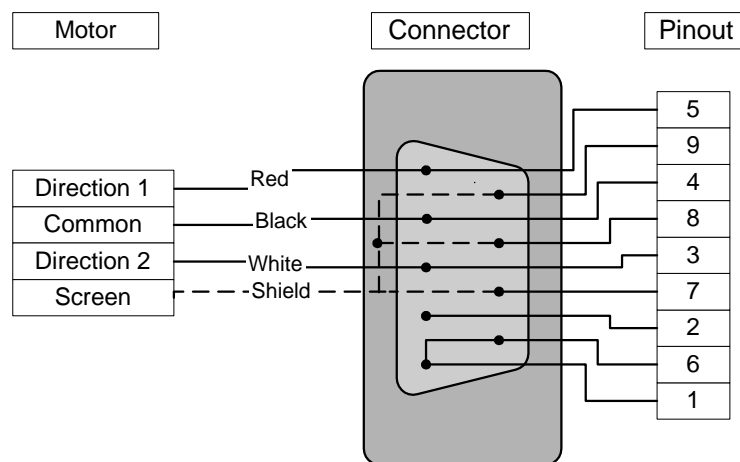

Figure 2: Driver Connector Pin Arrangement

Note:

- For safety reasons, the driver voltage is disabled unless pins 1 and 6 are shorted when the motor is connected



WARNING!

High voltage! Do not remove the cover of the motor or disassemble its connector.

3 Motor Conditioning

In order to ensure proper Motor operation, reduce wear rate of the system and to increase its lifetime, it is important that the Motor is run-in before normal use. Following is the list of conditions for the ST motor conditioning.

- Velocity - 100 mm/sec
- Duty cycle - 50%
- Duration - 4 hours

Once the Run-in is completed, carefully clean the ceramic strip with a Q-Tip soaked in IPA, **without dismounting the motor.**



Do not perform the Run-in procedure in a vacuum environment.

4 Technical Data

4.1 Specifications

Performance	
Maximum Allowable Velocity	250 [mm/sec]
Dynamic Stall Force	1.3 [N]
Static Holding Force	1.3 [N] (reference value)
Non-Energized Stiffness	0.15 [N/ μ]
Nominal Preload on Stage	9 [N]
Offset	0 to 2 [V] - Driver dependant
Attainable Resolution	Better than 50 nm – See application notes
Nominal Lifetime	20,000 hours under nominal operating conditions
Electrical	
Maximal Voltage	170 Vrms, sine wave
Maximal Current consumption	80 mA rms (Cable length dependant)
Maximal Power Consumption	3.5W
Environmental	
Ambient Working Temperature	0 - 50°C
Vacuum level	10 ⁻⁷ Torr (guaranteed only after baking)
Storage	-40°C - +70°C
Humidity	0 - 80% non condensing
Physical Dimensions	
Weight	5.5gr

5 Envelop of Performance (EOP)

The following graph (see Figure 3) illustrates motor velocity as a function of the applied driver command voltage. Allowing up to 30 mm/sec variations, use it as a reference and as a guideline for expected motor performance.

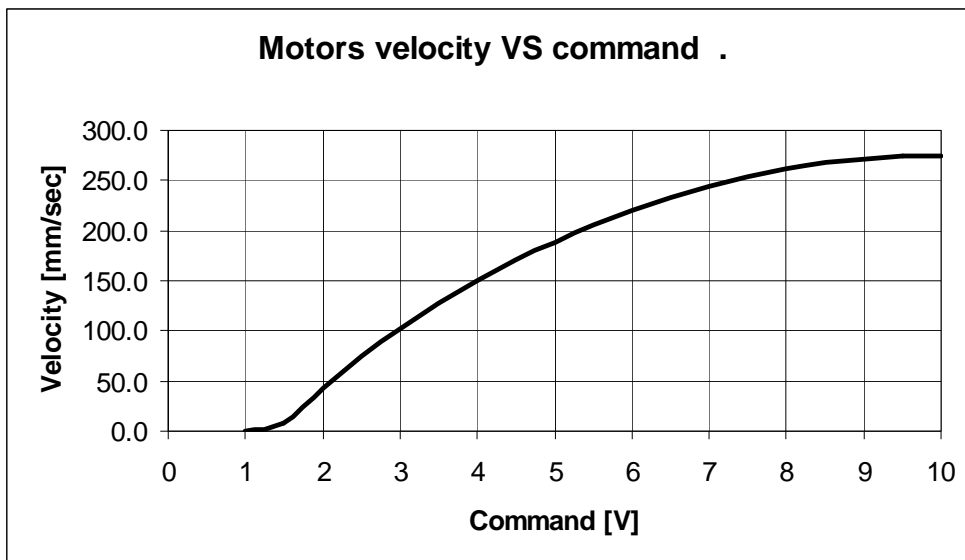

Figure 3: Motor Velocity vs. Command

 **WARNING!**

The EOP depicted herein should not be used when operating the motor with the AB5 driver. Otherwise, irreversible damage to the motor may result.

Please consult Nanomotion for the correct EOP with the AB5 driver.

The following graph (see Figure 4) and table are designed to help the user determine the correct performance envelope of operation so as to not overheat and damage the motor.

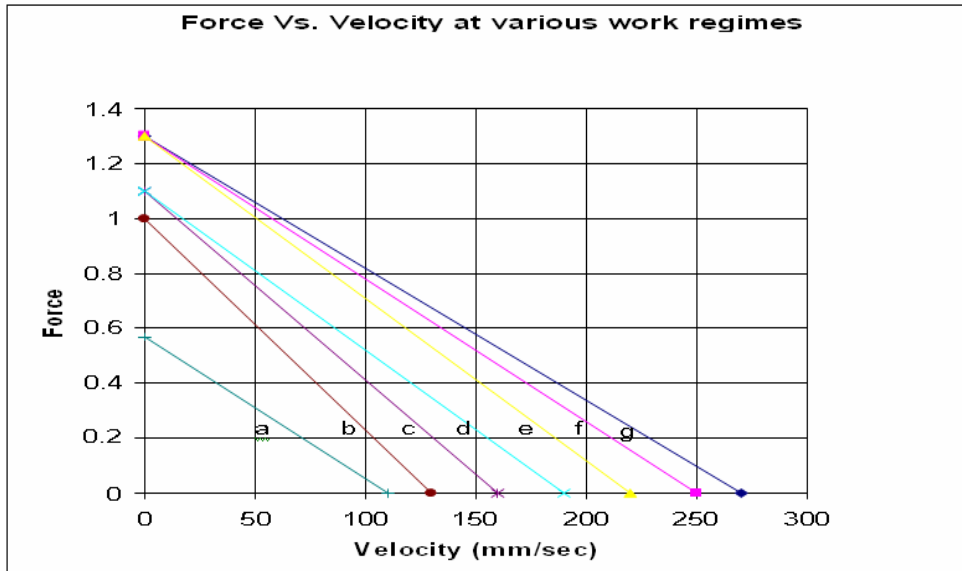

Figure 4: Force vs. Velocity at Various Work Regimes

Curve	Air 25°C		Vacuum 25°C	
	Duty Cycle [%]	Maximal Continuous Operation time [sec]	Duty Cycle [%]	Maximal Continuous Operation time [sec]
a	100	∞	100	∞
b	100	∞	40	60
c	100	∞	30	35
d	90	70	25	30
e	80	50	11	20
f	70	40	10	15
g	60	30	9	8

Table 1: EOP

5.1 Defining the EOP

An example for using the above graph and table:

A *vacuum* application requires $0.6N$ at a velocity of $50mm/sec$. The graph shows that this point of operation corresponds to curve “b”.

The table shows that curve “b” in vacuum environment require that a duty cycle of 40% will not be exceeded while maintaining a maximum continuous operation time of 60 seconds.

5.2 Considerations for Heat Dissipation in Vacuum Environment

Heat dissipation mechanism is based on radiation to the motor case and by conduction through the finger. Hence, the motor and the ceramic drive strip bases, must both be thermally designed to dissipate $0.25W$ each (per motor), with a temperature rise of $15^{\circ}C$ maximum. Also, the temperature of all parts in contact with the motor and with the ceramic drive strip should not exceed $30^{\circ}C$.

