



A Johnson Electric Company

RC3

Ultrasonic Motor

User Manual

D/N: RC03458000-00 REV: F

September 2009

Nanomotion Ltd. POB 623, Yokneam 20692, Israel

Tel: 972-73-2498000 Fax: 972-73-2498099

Web Site: www.nanomotion.com

E-mail: nano@nanomotion.com

Copyright

October 2000. This document contains proprietary information of Nanomotion, Ltd. and may not be reproduced in any form without prior written consent from Nanomotion Ltd.

Limited Warranty

Nanomotion (hereinafter NM) warrants the product (other than software) manufactured by it to be free from defects in material and workmanship for a period of time of one year (except those parts normally considered as consumable/expendable components such as motor conditioning brushes). The warranty commences thirty (30) days from the date of shipment.

NM warrants those parts replaced under warranty for a period equal to the remaining warranty coverage of the original part.

NM's sole and exclusive obligation under this warranty provision shall be to repair, or at its sole option exchange defective products or the relevant part or component, but only if : (i) the Purchaser reports the defect to NM in writing and provides a description of the defective product and complete information about the manner of its discovery within ten (10) days of its discovery; (ii) NM has the opportunity to investigate the reported defect and determines that the defect arises from faulty material, parts or workmanship; and (iii) the Purchaser returns the affected product to a location designated by NM. These provisions constitute the exclusive remedy of the Purchaser for product defects or any other claim of liability in connection with the purchase or use of NM products.

This warranty policy applies only to NM products purchased directly from NM or from an authorized NM distributor or representative.

This warranty shall not apply to (i) products repaired or altered by anyone other than those authorized by NM; (ii) products subjected to negligence, accidents or damage by circumstances beyond NM control; (iii) product subjected to improper operation or maintenance (i.e. operation not in accordance with NM Installation Manuals and/or instructions) or for use other than the original purpose for which the product was designed to be used.

The warranty stands only when the motors are used with the NM drivers/ amplifiers.

NM shall not in any event have obligations or liabilities to the Purchaser or any other party for loss of profits, loss of use or incidental, increased cost of operation or delays in operation, special or consequential damages, whether based on contract, tort (including negligence), strict liability, or any other theory or form of action, even if NM has been advised of the possibility thereof, arising out of or in connection with the manufacture, sale, delivery, use, repair or performance of the NM products. Without limiting the generality of the preceding sentence, NM shall not be liable to the Purchaser for personal injury or property damages.

CE Compliance

The Nanomotion's family of drivers and motors complies to the following directives:

Safety : IEC 61010-1:1990

EMC :89/336/EEC as amended by 92/31/EEC and 93/68/EEC

Harmonized Standards to which conformity is declared:

EN 50081- 2:1993/EN 55011:1991

Generic Emission Standards Class A for radiated emission and Class B for conducted emission.

EN 50082- 2:1995 Generic Immunity Standard

NOTE: Standard Nanomotion motors comply with CE regulations. Although the RC3 motors have the same internal design as the standard motors, they are supplied as components for the vacuum system and therefore, CE conformity in both EMI and Safety must be implemented as part of the UHV system design.

Preface

This Installation Manual is designed to help the reader install and operate the RC3 Piezo-ceramic Motor. This manual assumes that the reader has a fundamental understanding of basic servo systems, as well as motion control concepts and applicable safety procedures.

The manual describes the physical dimensions as well as the mechanical and electrical installation procedures for these motors.

Warranty

The motors are covered by warranty for a period of twelve months from the date of invoice.

The following voids the warranty:

Misuse or incorrect mounting, incorrect electrical connections, removal of motor cover or of serial number, modification of parts, and any other use that is not according to the cautions and warnings provided in this guide.

Liability for replacement will be determined after inspection of any defective item by Nanomotion or an approved agent.

Definition of Terms

NOTE: *Additional useful information.*

CAUTION: *Identifies conditions or practices that could result in damage to this product or other property.*



WARNING: *Identifies conditions or practices that could result in personal injury, damage to the product or other property.*

Warnings and Cautions



WARNINGS

Do not attempt to open the motor. High voltage inside.

Be sure to ground the motor to the electrical network ground before operating.

CAUTIONS

- *Avoid mechanical stress on the flex tail.*
- *Do not set power-on unless motor is mounted and preloaded!*
- *Do not immerse the motor in any liquid or cleaning agent.*
- *Use only a clean cloth to wipe the motor.*
- *Be sure that the motor, and specifically the 'finger tips', are not subjected to mechanical shocks.*
- *Be sure that the distance of the motor to the plate enables the motor finger tip to contact the driving plate, otherwise the motor might be damaged during operation.*
- *The mounting base and the method used for mounting should be designed for maximum mechanical rigidity and stiffness.*

Table of Contents

1. INTRODUCTION	7
1.1 About the Motor	7
1.2 Handling	8
1.3 Installation and Servicing	8
2. PREPARATION AND INSTALLATION	9
2.1 Overview	9
2.2 Bonding the Driving Plate to the Stage	9
2.2.1 Mounting the motor.....	12
2.2.2 Electrical Connection.....	12
2.2.3 Motor Grounding.....	12
2.2.4 Motor Run-In.....	13
3. SPECIFICATIONS	14
3.1 General	14
3.2 Specification Parameters	16
3.2.1 Specifications.....	16
3.2.2 Materials Comprising the Motor.....	17
3.2.3 Performance Envelope.....	18
3.3 Dimensions Layout	20

1. Introduction

1.1 About the Motor

RC3 motors are high precision ceramic motors. Designed and manufactured by Nanomotion, Ltd., these motors combine unlimited stroke with high resolution, all in a compact package.

RC3 motors provide a linear response to the input voltage. The operation of the motor and driver resembles that of a DC-motor driven by a voltage amplifier.

The RC3-HV and RC3-UHV motors are constructed of materials that have been selected and designed for high vacuum compatibility.

NOTE: *The specifications described in this manual apply only to the motor driven by the PD7 driver box.*

1.2 Handling

CAUTIONS

Avoid mechanical stress on the flex tail.

Do not set power-on unless the motor is mounted and preloaded!

Do not immerse the motor in any liquid or cleaning agent.

Use only a clean cloth to wipe the motor.

Be sure that the motor, and specifically the 'finger tips', are not subjected to mechanical shocks.

1.3 Installation and Servicing

It is recommended to follow the installation instructions in this guide, when mounting and installing the motor.

The RC3 motor does not contain any user-serviceable parts.

2. Preparation and Installation

2.1 Overview

The installation procedure consists of the following:

- Bonding the Ceramic Driving plate to the stage
- Mounting the motor
- Grounding the motor
- Connecting the motor to its driver

2.2 Bonding the Driving Plate to the Stage

The Driving Ceramic Plate interfaces between the motor 'finger tips' and the stage, providing the required friction.

Bond the driving plate to the stage surface interfacing with the motor 'finger tips', according to the instructions given in this section.

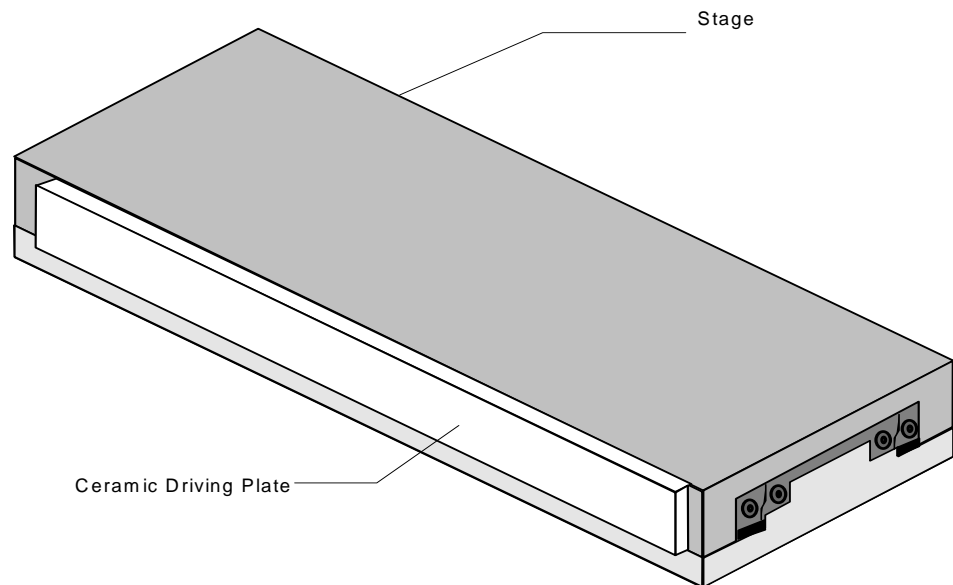

Figure 1: Bonding the Ceramic Driving Plate

1. Clean the bonding region on the stage, using a suitable agent such as acetone or methanol.
2. Peel off the self-adhesive tape on the Ceramic driving plate. The self adhesive tape is compatible with high-vacuum applications.
3. Referring to the figure below, position the plate, so that there is a distance of *at least* 0.5mm between the edges of the ceramic plate and the finger-tips.

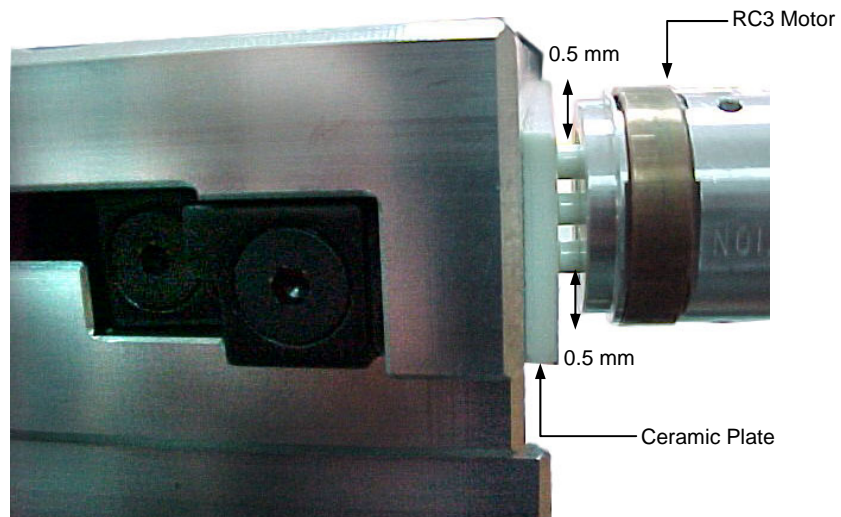

Figure 2: Ceramic Drive Plate Position

- Referring to the Figure 3, apply *at least* two drops of epoxy adhesive (about 2cm apart), to the center of the Ceramic driving plate *upper* surface. The Epoxy must bond the plate and the stage.

Recommended adhesive: Emerson & Cuming ecobond 24 (vacuum compatible).

NOTE: *Be sure the epoxy contacts the upper surfaces of the plate and the stage carriage, but that no excess glue flows over the Ceramic plate front surface.*

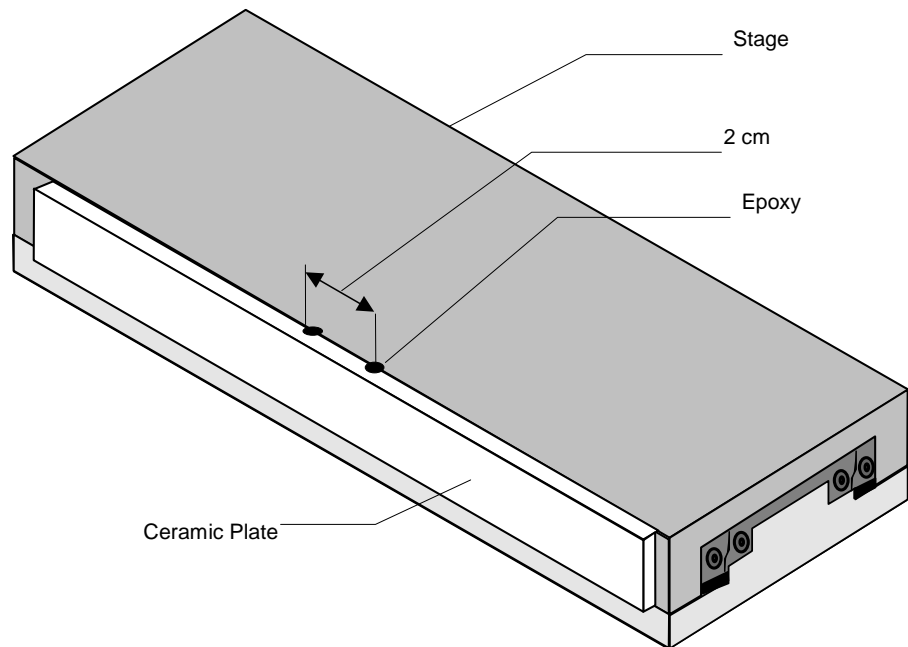

Figure 3: Securing the Ceramic Driving Plate to the Stage

- Allow the required time period for curing, according to the Epoxy manufacturer specifications.
- Mount the motor according to the following section.

2.2.1 Mounting the motor

The motor is inserted into the mounting base hole. Make sure all of the dimensions and tolerances specified in the figure below are met.

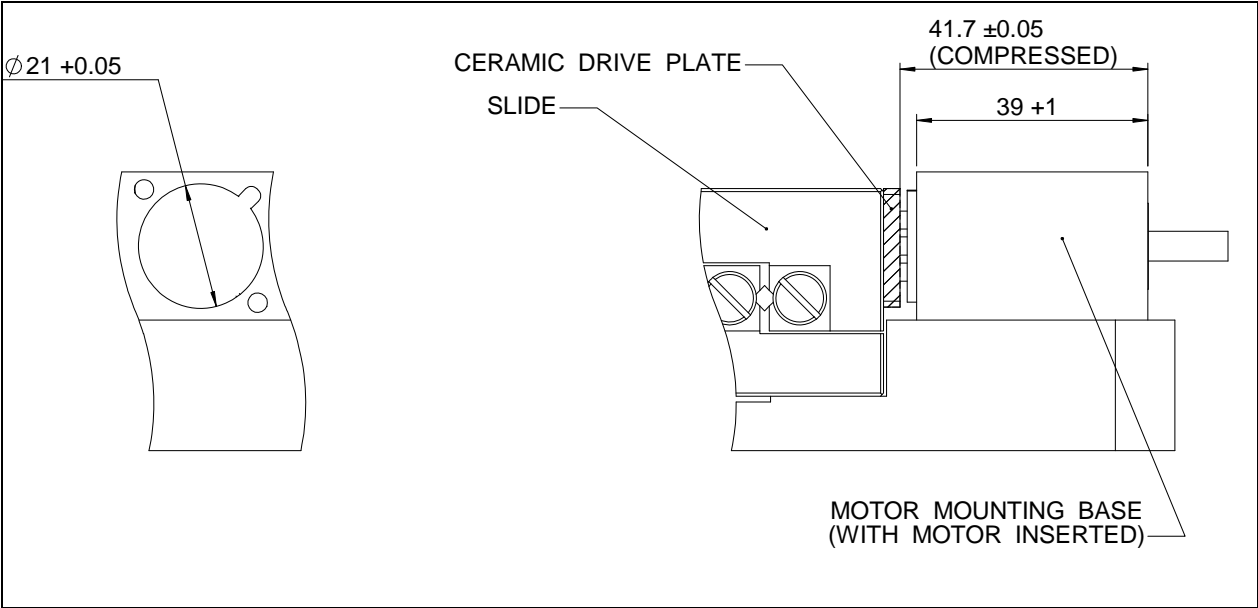

Figure 4: Motor Mounting (dimensions in mm)

2.2.2 Electrical Connection

Wire the electrical connections to the flex tail using an AMP connector, model 487951-4.

2.2.3 Motor Grounding

The motor's mounting base should be grounded to the main ground.

2.2.4 Motor Run-In

Be sure to perform motor run-in in an ambient environment in order to reduce the wear rate of the system and to prolong its lifetime.

The required run-in conditions are as follows:

- Velocity - 50 mm/sec.
- Duty cycle - 50%.
- Duration - 4 hours.

General remarks:

1. Be sure to operate the motors using only drivers supplied by Nanomotion and the correct resonance circuit.
2. The procedure should be repeated if the motor is disconnected and reinstalled.
3. **Do not perform run-in within a vacuum environment.**

3. Specifications

3.1 General

These specifications apply to the motor driven by the PD7 Driver Box. The motor features a linear voltage response. The motor and driver can be modeled as a DC-motor with friction driven by a voltage amplifier, as illustrated in the following diagram. .

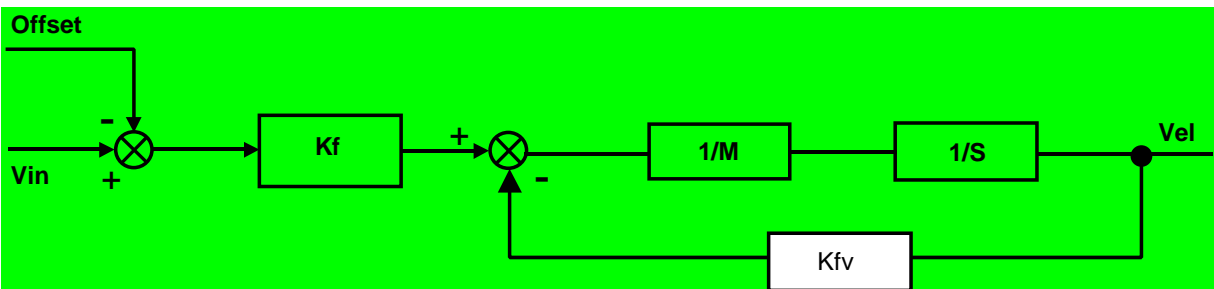

Figure 5: *Block Diagram of the Motor and Driver*

Where:

- V_{in} - Command to the driver -10 to +10 [V]
- K_f - Force constant [N/V]
- $Offset$ - Starting voltage [V]
- K_{fv} - Velocity damping factor
(similar to back EMF) [N x sec / m]
- Vel - Motor velocity [m/Sec]
- M - Moving mass [kg]
- S - Laplace variable [1/sec]

A block diagram of a typical RC3 Driver/Motor Sub-system is illustrated in Figure 5.

A command voltage of $\pm 10V$ is applied to the driver, which then generates a 40.5Khz sine wave (V motor) whose amplitude is a function of command voltage. The sine wave drives the RC3 motor.

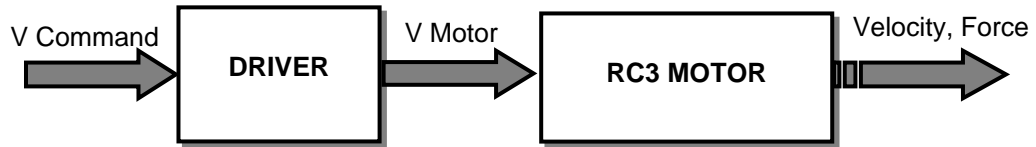

Figure 6: *Block Diagram of a typical RC3 Driver/Motor Sub-system*

3.2 Specification Parameters

3.2.1 Specifications

Performance

Maximum Velocity:	180 [mm/sec] (min).
Dynamic Stall Force:	12 [N] (min)
Force @ 80 mm/sec	8.5 [N] (min)
Non-Energized Stiffness	1.8 [N/ μ] (min) (less for HV motor)
Nominal Preload on Stage	50 [N]
Kf	2.7 \pm 40% [N/Volt command]
Kfv	50 \pm 20% [N • sec/m]
Offset	1 to 2 [V]
Attainable Resolution	Better than 100nm – See application notes
Nominal Lifetime	20,000 hours under nominal operating conditions

Electrical

Maximal Voltage:	280Vrms, 40.5KHz, sine wave
Maximal Current consumption:	270mA rms \pm 30mA
Maximal Power Consumption:	17W \pm 2W (zero W at hold)
Electrical Connection	4 contact edge connector on FPC

Environmental

Ambient Temperature:	0 - 50°C
Storage:	-20°C - +70°C
Humidity:	0 - 80% non condensing
Vacuum level (ultra-high-vacuum motors):	10 ⁻¹⁰ Torr (guaranteed only after baking)
Maximal Baking Temperature	140°C

Physical Dimensions

Diameter	Ø21mm
Length	41.7mm
Weight	34 gr.

3.2.2 Materials Comprising the Motor

AL 2024-T6

Peek

Viton

Conifer

Tellurium Copper

Silver coated Tellurium Copper

Fired Silver Electrodes PZT

Alumina

Vacuum Epoxy

Kapton – Pyralux Flexible Printed Circuit

SS AISI 304

3.2.3 Performance Envelope

The following graph illustrates motor velocity as a function of the applied driver command voltage under no load. Allowing up to 30 mm/sec variations, use it as a reference and as a guideline for expected motor performance,

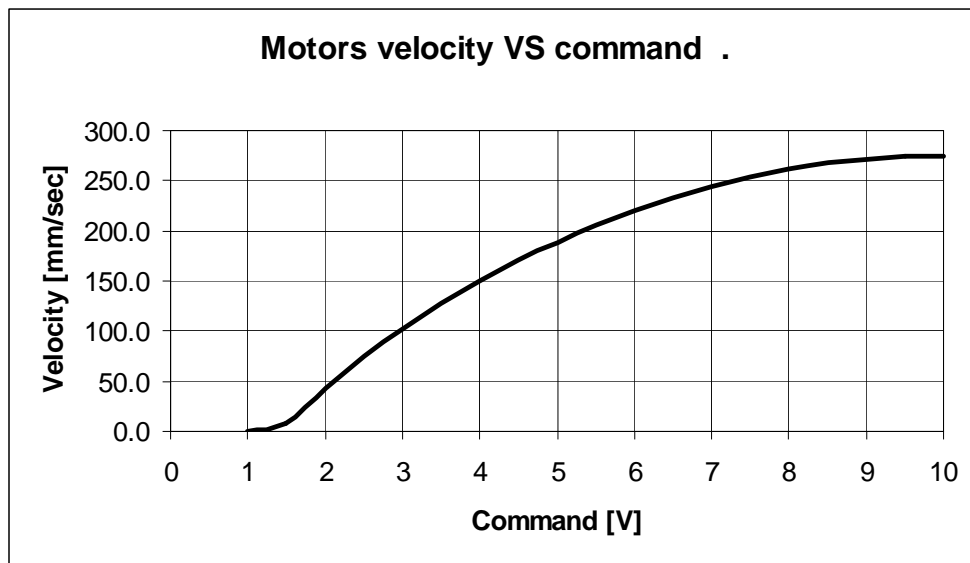
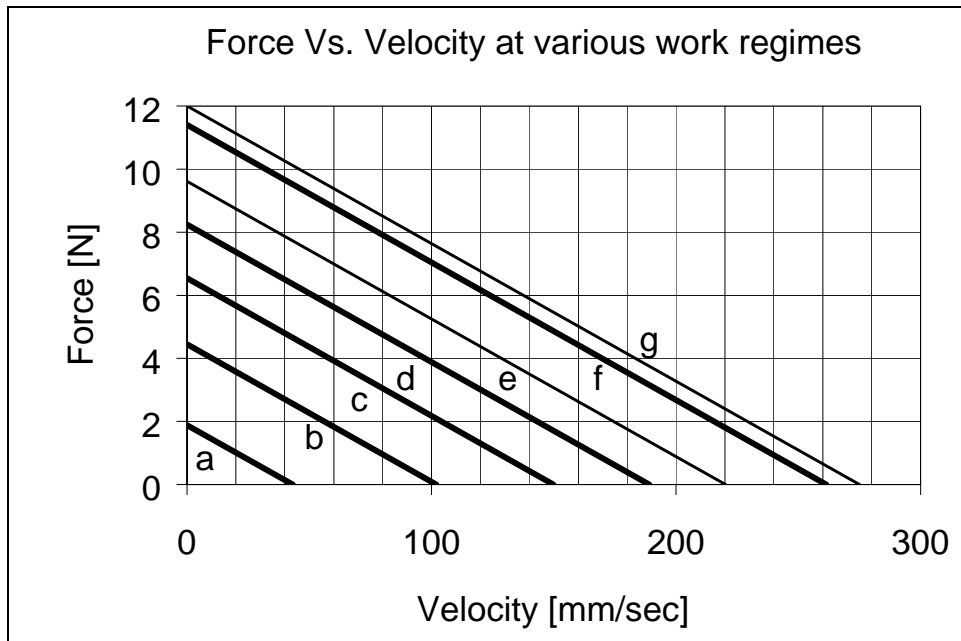

Figure 7: Motor Velocity vs. Command¹

¹ The motor operates horizontally at room temperature and low duty cycle (< 10%). It interfaces a Ceramic Strip (according to Nanomotion Specifications) and a cross-roller high quality slide.

The following graph and table are designed to help the user determine the correct performance envelope of operation so as to not overheat and damage the motor.



Curve	25°C		50° C		VACUUM	
	Duty Cycle	Maximum Continuous Cycle Operation (sec)	Duty Cycle	Maximum Continuous Cycle Operation (sec)	Duty Cycle	Maximum Continuous Cycle Operation (sec)
a	100%	-	100%	-	100%	-
b	100%	-	100%	-	44%	184
c	100%	-	92%	137	26%	107
d	100%	-	62%	93	17%	72
e	78%	87 sec.	47%	70	13%	55
f	56%	63 sec.	33%	50	9%	39
g	50%	56 sec.	30%	45	8%	35

Figure 8: Performance Envelope At Various Work Regimes

Defining a performance envelope (example of the use of the above graph and table)

A *vacuum* application requires 4N at a velocity of 60mm/sec. The graph shows that this point of operation corresponds to curve “c”. The table shows that curve “c” and a vacuum environment require that a duty cycle of 26% will not be exceeded while maintaining a *maximum* continuous operation time of 107 seconds.

Vacuum application note – Heat dissipation mechanism is by radiation to the motor case and by conduction through the fingers. Hence, the motor and the ceramic drive strip bases, must both be thermally designed to dissipate 0.75W each (per motor), with a temperature rise of 15°C maximum. Also, the temperature of all parts in contact with the motor and with the ceramic drive strip, should not exceed 40°C.

3.3 Dimensions Layout

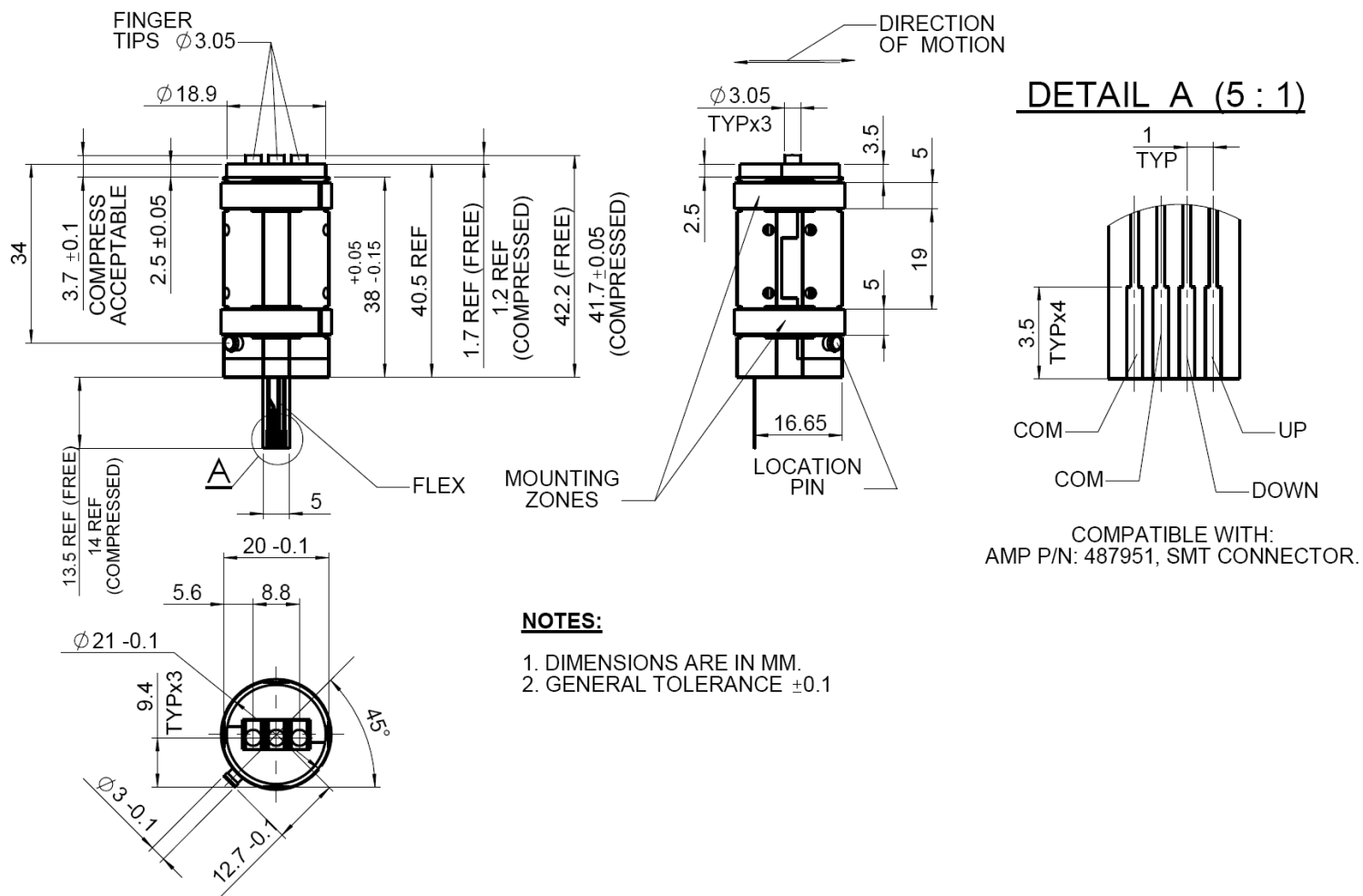

Figure 9: Dimensions Layout