



# EDGE Motor Evaluation Kit Application Guide



EDGE458000-00 REV:A

July 2009

---

Nanomotion Ltd. POB 623, Yokneam 20692, Israel

Tel: 972-73-2498000 Fax: 972-73-2498099

Web Site: [www.nanomotion.com](http://www.nanomotion.com)

E-mail: [nano@nanomotion.com](mailto:nano@nanomotion.com)

## Copyright

This document contains proprietary information of Nanomotion Ltd., and may not be reproduced in any form without prior written consent from Nanomotion Ltd.

No part of this document may be reproduced, translated, stored in a retrieval system or transmitted in any form and by any means, electronic, mechanical, photographic, photocopying, recording, or otherwise, without the written permission of Nanomotion Ltd.

Information provided in this document is subject to change without notice and does not represent a commitment on the part of Nanomotion Ltd.

Copyright February 2009, Yokneam, Israel. All rights reserved.

All products and company names are trademarks or registered trademarks of their respective holders.

## Limited Warranty

Nanomotion Ltd. (hereinafter NM) warrants the product (other than software) manufactured by it to be free from defects in material and workmanship for a period of time of one year (except those parts normally considered as consumable/expendable components such as motor conditioning brushes). The warranty commences thirty (30) days from the date of shipment.

NM warrants those parts replaced under warranty for a period equal to the remaining warranty coverage of the original part.

NM's sole and exclusive obligation under this warranty provision shall be to repair, or at its sole option exchange defective products or the relevant part or component, but only if: (i) the Purchaser reports the defect to NM in writing and provides a description of the defective product and complete information about the manner of its discovery within ten (10) days of its discovery; (ii) NM has the opportunity to investigate the reported defect and to determine that the defect arises from faulty material, parts or workmanship; and (iii) the Purchaser returns the affected product to a location designated by NM. These provisions constitute the exclusive remedy of the Purchaser for product defects or any other claim of liability in connection with the purchase or use of NM products.

This warranty policy applies only to NM products purchased directly from NM or from an authorized NM distributor or representative.

This warranty shall not apply to (i) products repaired or altered by anyone other than those authorized by NM; (ii) products subjected to negligence, accidents or damage by circumstances beyond NM control; (iii) product subjected to improper operation or maintenance (i.e. operation not in accordance with NM Installation Manuals and/or instructions) or for use other than the original purpose for which the product was designed to be used.

NM shall not in any event have obligations or liabilities to the Purchaser or any other party for loss of profits, loss of use or incidental, increased cost of operation or delays in operation, special or consequential damages, whether based on contract, tort (including negligence), strict liability, or any other theory or form of action, even if NM has been advised of the possibility thereof, arising out of or in connection with the manufacture, sale, delivery, use, repair or performance of the NM products. Without limiting the generality of the preceding sentence, NM shall not be liable to the Purchaser for personal injury or property damages.

This page is left blank intentionally.

## Table of Contents

|   |           |
|---|-----------|
| <b>1 GENERAL</b> .....                  | <b>8</b>  |
| 1.1 Introduction .....                  | 8         |
| 1.2 EDGE Evaluation Kit Content .....   | 8         |
| <b>2 SYSTEM DESCRIPTION</b> .....       | <b>9</b>  |
| 2.1 Configuration Options .....         | 9         |
| 2.2 Motion Module .....                 | 10        |
| 2.3 Interface Box.....                  | 10        |
| 2.4 ASIC Driving Modes.....             | 11        |
| 2.5 Analog Input Connection.....        | 12        |
| <b>3 SYSTEM OPERATION</b> .....         | <b>13</b> |
| 3.1 Open Loop Operation Mode.....       | 13        |
| 3.2 Close Loop Operation Mode .....     | 15        |
| <b>4 TECHNICAL DATA</b> .....           | <b>17</b> |
| 4.1 Input Connectors' Pinouts .....     | 17        |
| 4.2 Cables' Layouts.....                | 18        |
| 4.3 Load Mounting Interface .....       | 19        |
| 4.4 Motion Module Layout.....           | 20        |
| <b>5 ORDERING INFORMATION</b> .....     | <b>22</b> |
| 5.1 Part Numbering Scheme.....          | 22        |
| 5.2 Example Configurations.....         | 22        |
| <b>6 CONTACT INFORMATION</b> .....      | <b>23</b> |
| 6.1 Customer Service.....               | 23        |
| 6.2 General Inquiries and Ordering..... | 23        |

## List of Figures

|   |    |
|---|----|
| Figure 1: EDGE Evaluation Kit Content .....                             | 8  |
| Figure 2: Motion Module Configuration Options .....                     | 9  |
| Figure 3: Motion Module Setup .....                                     | 10 |
| Figure 4: Interface Box Controls .....                                  | 10 |
| Figure 5: Differential Analog Input Connection .....                    | 12 |
| Figure 6: Non-Differential (single-ended) Analog Input Connection ..... | 12 |
| Figure 7: System Connection.....  | 13 |
| Figure 8: Interface Box.....  | 14 |
| Figure 9: System Connection.....  | 15 |
| Figure 10: Driver Control Cable Layout .....                            | 18 |
| Figure 11: Controller Adaptor Cable Layout .....                        | 18 |
| Figure 12: Linear Slide Properties .....                                | 19 |
| Figure 13: Motion Module Layout .....                                   | 20 |
| Figure 14: Rotary Mounting Ring for Motion Module .....                 | 21 |

## List of Abbreviations

|       |  |
|-------|--|
| IIC   | Inter-Integrated Circuit<br>Serial Communication Interface |
| ASIC  | Application Specific Integrated Circuit                    |
| AC    | Alternating Current  |
| DC    | Direct Current   |
| LED   | Light Emitting Diode                                       |
| RS232 | Serial Communication Protocol                              |
| PCB   | Printed Circuit Board                                      |

# 1 General

## 1.1 Introduction

The purpose of this application guide is to help the reader operate the EDGE Evaluation Kit.

The EDGE Evaluation Kit allows to operate and evaluate the Nanomotion EDGE motor characteristics in close loop or open loop. The Evaluation Kit consists of the EDGE motor, assembled on a Motion Module, together with the ASIC driver and of a multipurpose Interface Box. The EDGE Evaluation Kit is available in configurations of open/close loop and linear/rotary, see section 2.1.

## 1.2 EDGE Evaluation Kit Content

- Motion Module: EDGE motor + ASIC driver; linear / rotary slide; 0.1 $\mu$  encoder (optional).
- Interface Box (including four AAA batteries) with integrated joystick.
- 5VDC power supply (P/N: EAE000031): Stontronics - 3A-181WP05 - adaptor, multi plug, 18W, 5V. When connected, overruns the batteries power source. Does not recharge the batteries.
- Driver Control cable.
- Controller Adaptor cable.
- Carrying case.



**Figure 1: EDGE Evaluation Kit Content**

## 2 System Description

### 2.1 Configuration Options

EDGE Evaluation Kit is available in four configurations:

- a) EDGE Evaluation Kit with linear slide and 0.1 $\mu$  Renishaw encoder for close loop operation.
- b) EDGE Evaluation Kit with linear slide – for operation in open loop.
- c) EDGE Evaluation Kit with linear slide and Micro-E encoder adaptor for close loop operation.
- d) EDGE Evaluation Kit with rotary slide – for operation in open loop.

See chapter 5 for Ordering Information.

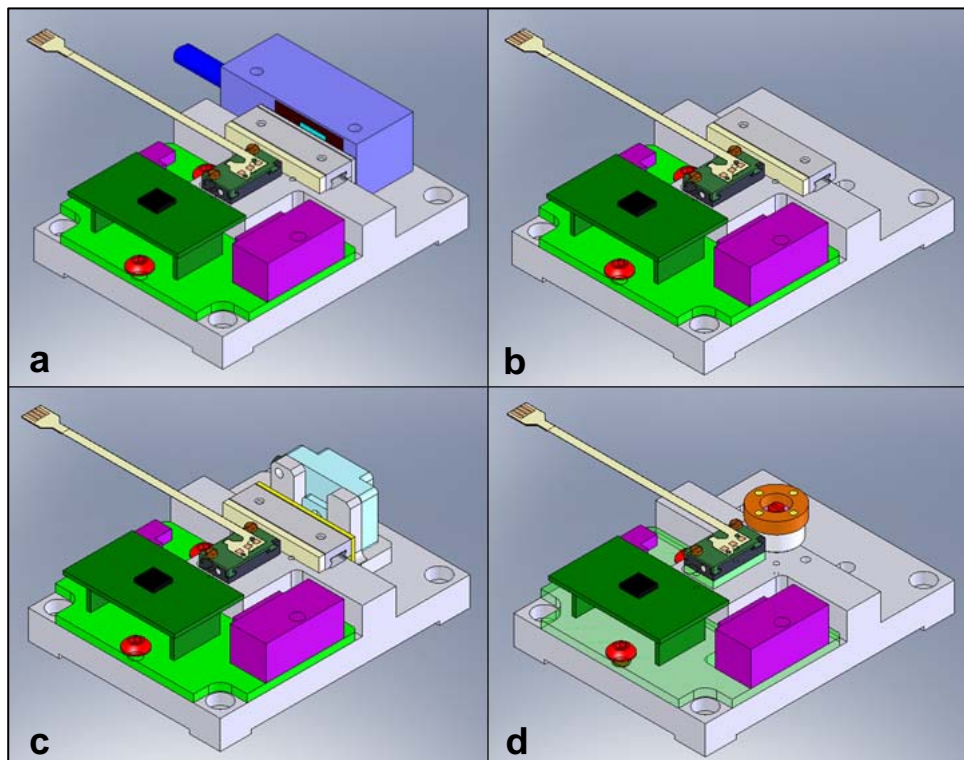

**Figure 2: Motion Module Configuration Options**

**Notes:**

- *The Interface Box is compatible for all above mentioned Motion Module configurations.*
- *Configuration C is provided without the Micro-E encoder and encoder scale.*

## 2.2 Motion Module

The motion module comprises of the EDGE motor driven by a custom ASIC driver PCB, which is connected to the stage, see Figure 3.

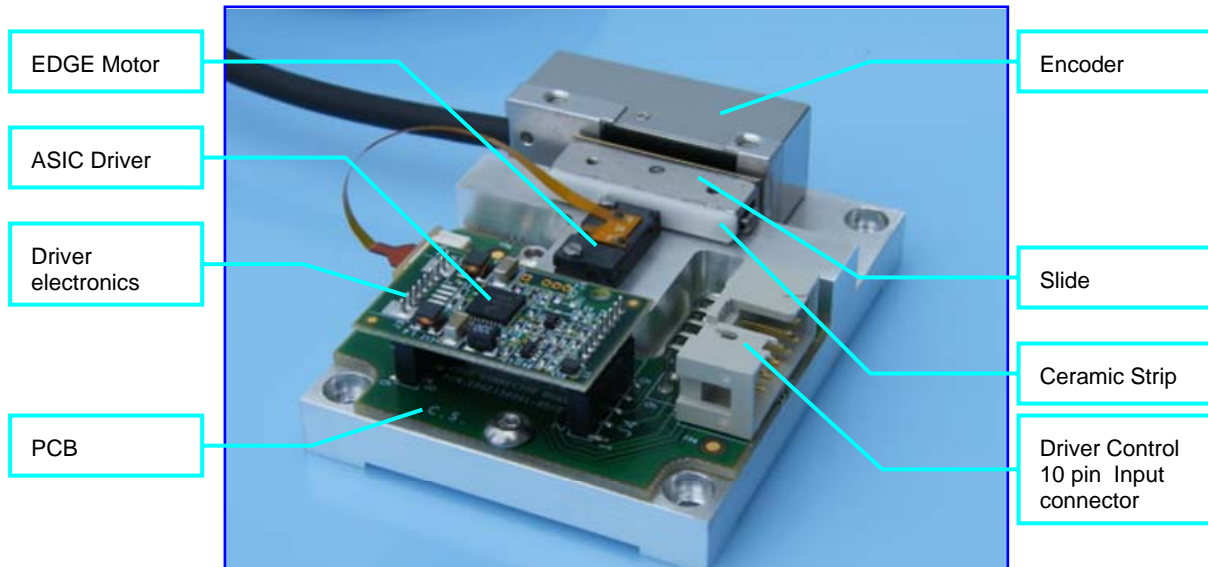

**Figure 3: Motion Module Setup**

The control signals and the power supply are provided from the Interface Box by means of Driver Control cable.

## 2.3 Interface Box

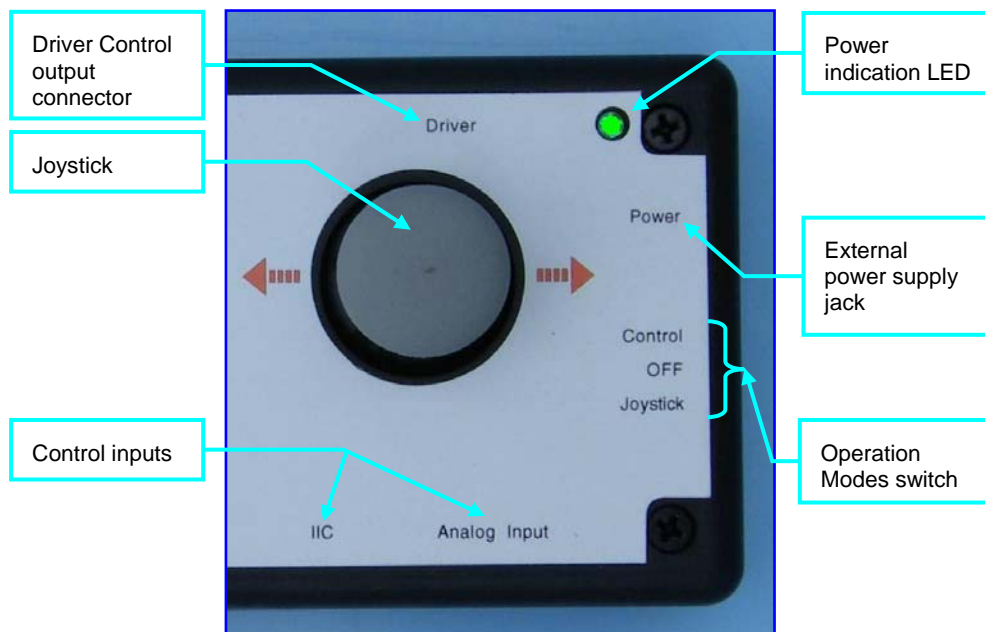

**Figure 4: Interface Box Controls**

The Interface Box integrates the following elements (refer to Figure 4):

- 'Driver' – 10 pin output connector for connecting the Interface Box to the Motion Module. Supplies Vcc of +4.2 V to the ASIC driver.
- 'Power' – 5VDC external power supply jack. When connected, overruns the batteries power source (four AAA cells), located inside the Interface Box.
- Operation Modes switch:
  - ◆ 'Control' – enables close loop control by using the Analog Input or IIC connection (for more details, see section 3.2 "Close Loop Operation Mode").
  - ◆ 'OFF' – switches power off.
  - ◆ 'Joystick' – enables manual control in open loop mode (for more details, see section 3.1 "Open Loop Operation Mode").
- 'IIC' / 'Analog Input' – provide the separate serial IIC connection or separate analog input connection for the user controller inputs (for more details, see sections 2.5 "Analog Input Connection" and 3.2 "Close Loop Operation Mode").

## 2.4 ASIC Driving Modes

In close loop the ASIC Driver can drive the motor in two driving modes (refer to section 3.2 for Close Loop Operation Mode):

- **AB1A Driving Mode** – standard motor operation mode. In this mode the motor is motionless up to approximately  $\pm 1.5V$  command. Nanomotion motion algorithm enables the motor smooth motion as well as micron level movement. This drive mode is the default mode for open / close loop.
- **AB5 Driving Mode** – this mode facilitates a linear response of the motor from 0 (zero) command level. This mode is recommended for scanning applications and micron-level movements.

## 2.5 Analog Input Connection

There are two options for the  $\pm 10V$  analog input connection:

- Differential connection:

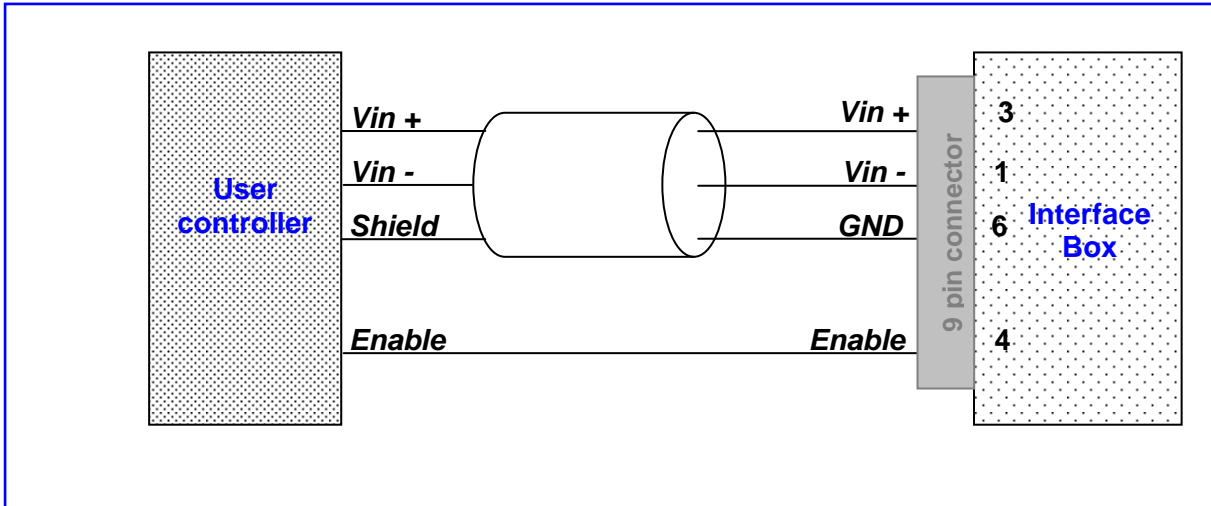

**Figure 5: Differential Analog Input Connection**

- Single-Ended (Non-differential) Connection:

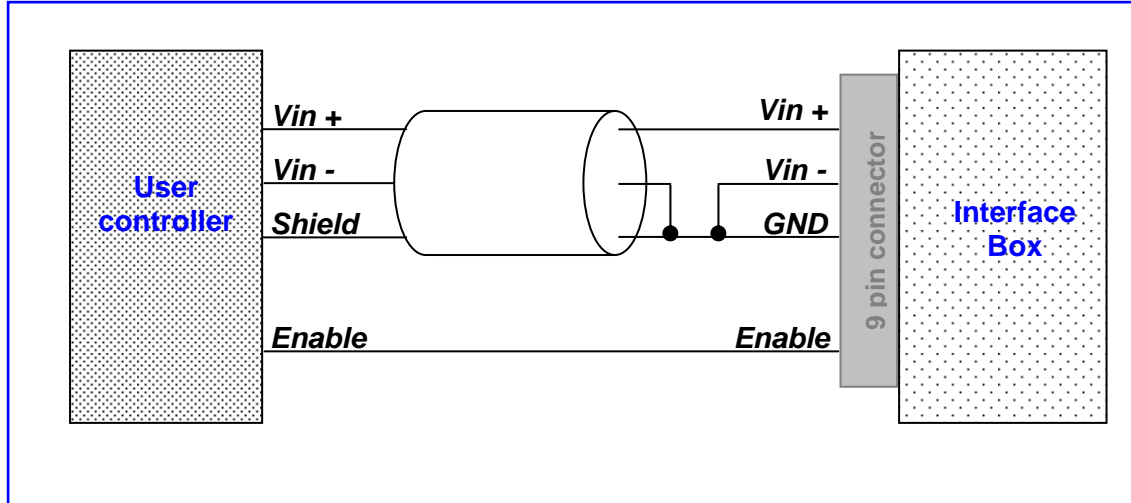

**Figure 6: Non-Differential (single-ended) Analog Input Connection**

**Note:**

- For Controller Adaptor cable pinout, refer to Table 1.

## 3 System Operation

The EDGE Evaluation Kit can be operated in two operation modes: Open Loop Mode and Close Loop Mode.

### 3.1 Open Loop Operation Mode

Open Loop Operation mode – allows manual control by using a joystick located on the Interface Box. For operating the motor in manual operation mode follow the steps below (refer to Figure 7 and Figure 8):

- 3.1.1 Connect the Driver Control cable between Interface Box 'Driver' output connector and Driver Control 10 pin input connector, located on the motion module, see Figure 7.



**Figure 7: System Connection**

- 3.1.2 Set the Operation Modes switch, located on the Interface Box, to 'Joystick' position, refer to Figure 8.
- 3.1.3 The system is now ready to operate, using the internal batteries' power. Alternatively, the user can connect the external power supply, refer to Figure 7.



**Figure 8: Interface Box**

3.1.4 Move the Joystick sideways according to the orange arrows marked on top of the Interface Box. The motor speed depends on the joystick direction and its tilt angle.

**Note:**

- Set the Operation Modes switch to 'OFF' after the operation is completed in order to save batteries.

## 3.2 Close Loop Operation Mode

To achieve optimal close loop control over the system, it is advised to use the Nanomotion controller from the LK product family or other Nanomotion approved controllers, which support Nanomotion control algorithm.

For operating the motor in close loop follow the steps below (refer to Figure 8 and Figure 9):

- 3.2.1 Connect the Driver Control cable between Interface Box 'Driver' output connector and Driver Control 10 pin input connector, located on the motion module, see Figure 9.

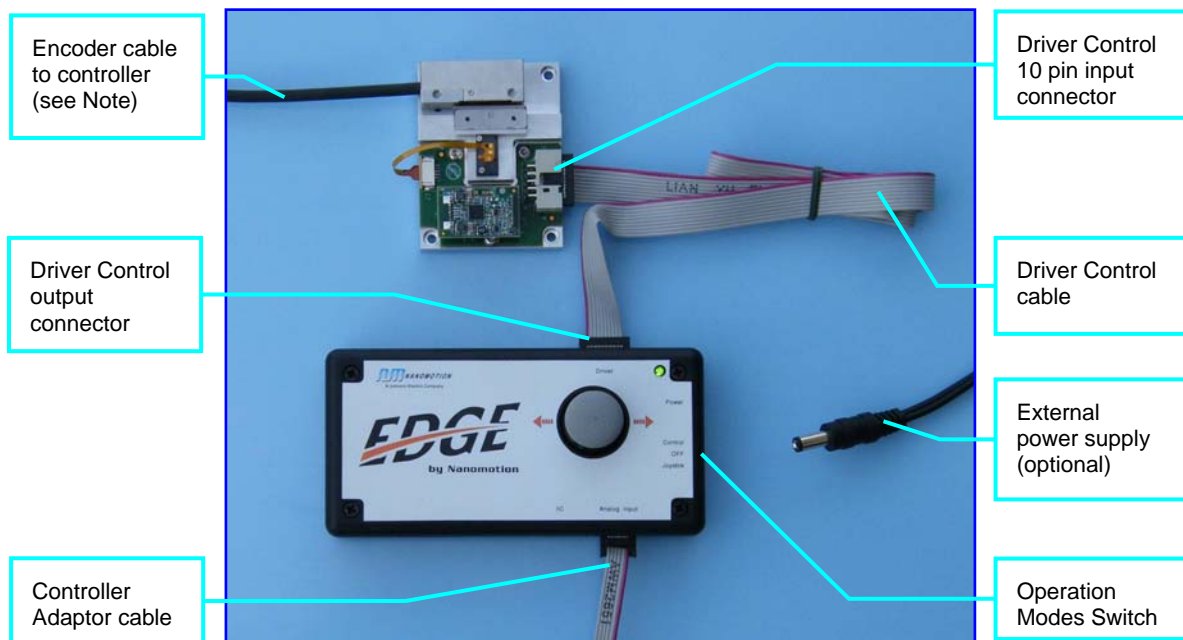

**Figure 9: System Connection**

- 3.2.2 The close loop control can be executed by using either IIC or the Analog Input connection as follows (refer to Figure 9):

- ◆ For Analog Input: connect the Controller Adaptor cable between the 'Analog Input' connector and the controller. For details, see section 2.5.
- ◆ Alternatively, for IIC: connect the Controller Adaptor cable between the 'IIC' connector and the controller.

**Note:**

- For Controller Adaptor cable pinouts, refer to Table 1 and Table 2.

- 3.2.3 Connect the encoder cable to controller's encoder input connector.
- 3.2.4 Set the Operation Modes switch, located on the Interface Box, to 'Control' position.
- 3.2.5 The system is now ready to operate using the internal batteries' power. Alternatively, the user can connect the external power supply, refer to Figure 9.
- 3.2.6 Tune control parameters according to the user's specific Nanomotion controller manual.
- 3.2.7 Choose driving mode (refer to section 2.4 for more details):
  - ◆ The AB1A mode is default.
  - ◆ In order to operate the motor in AB5 mode, short pin 2 of the Analog Input Connector to ground, refer to Table 1 in section 4.1.

**Note:**

- *Set the Operation Modes switch to 'OFF' after the operation is completed in order to save batteries.*

## 4 Technical Data

### 4.1 Input Connectors' Pinouts

The close loop control is available by using either IIC or the Analog Input connection, as follows:

- 

| Pin # | Pin Name    | Function                                |
|-------|-------------|---|
| 1     | -Vin        | Input Analog voltage ( - )              |
| 2     | Driver Mode | AB1A default<br>Mode AB5 – short to GND |
| 3     | +Vin        | Input Analog voltage (+)                |
| 4     | Enable 1    | Enable<br>* Active – short to GND       |
| 5     | N.C.        | Not connected                           |
| 6     | GND         | Ground                                  |

**Table 1: Analog Input Connector Pinout**

- IIC Connector Pinout

| Pin # | Pin Name | Function                          |
|-------|----------|-----------------------------------|
| 1     | SDATA    | IIC Serial Data                   |
| 2     | SCLK     | Serial Clock                      |
| 3     | + 5V     | Vcc for additional IIC (optional) |
| 4     | GND      | Ground                            |
| 5     | + 5V     | Vcc for additional IIC (optional) |
| 6     | GND      | Ground                            |

**Table 2: IIC Connector Pinout**

## 4.2 Cables' Layouts

- Driver Control cable layout:

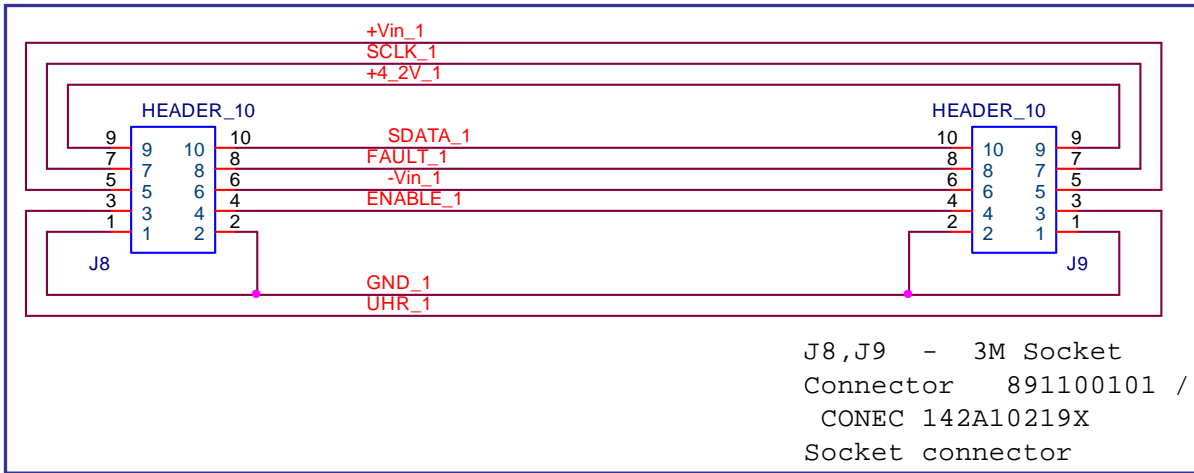

**Figure 10: Driver Control Cable Layout**

- Controller Adaptor cable layout:

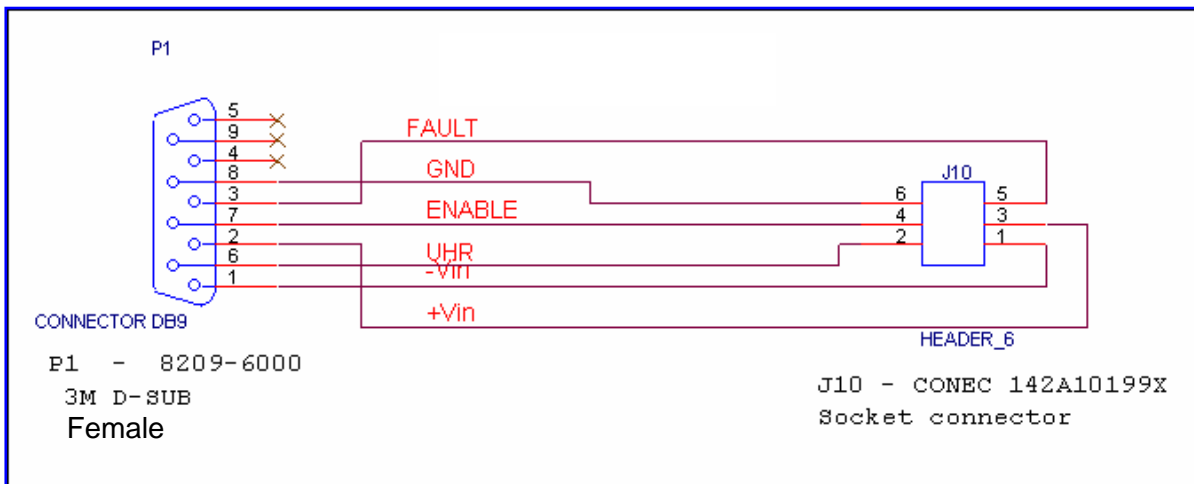

**Figure 11: Controller Adaptor Cable Layout**

### 4.3 Load Mounting Interface

The user can mount a load on both linear and rotary slides as follows: vertical load of 100 gr., horizontal load of 10 gr. Refer to Figure 12 and Table 3 for mounting properties.

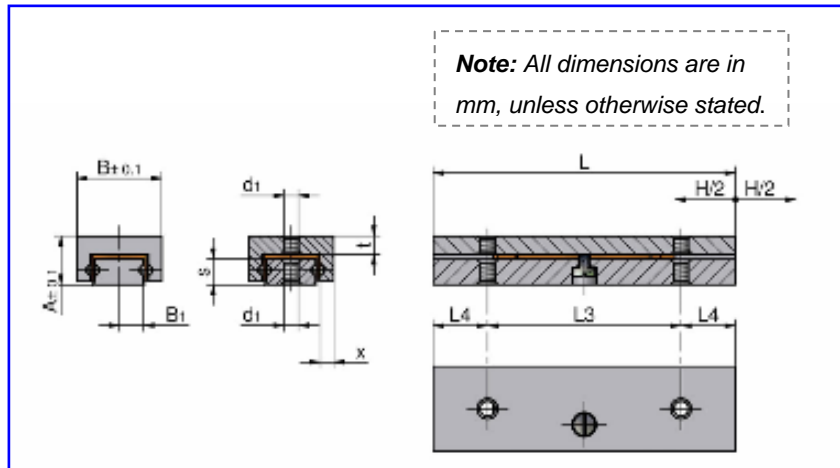
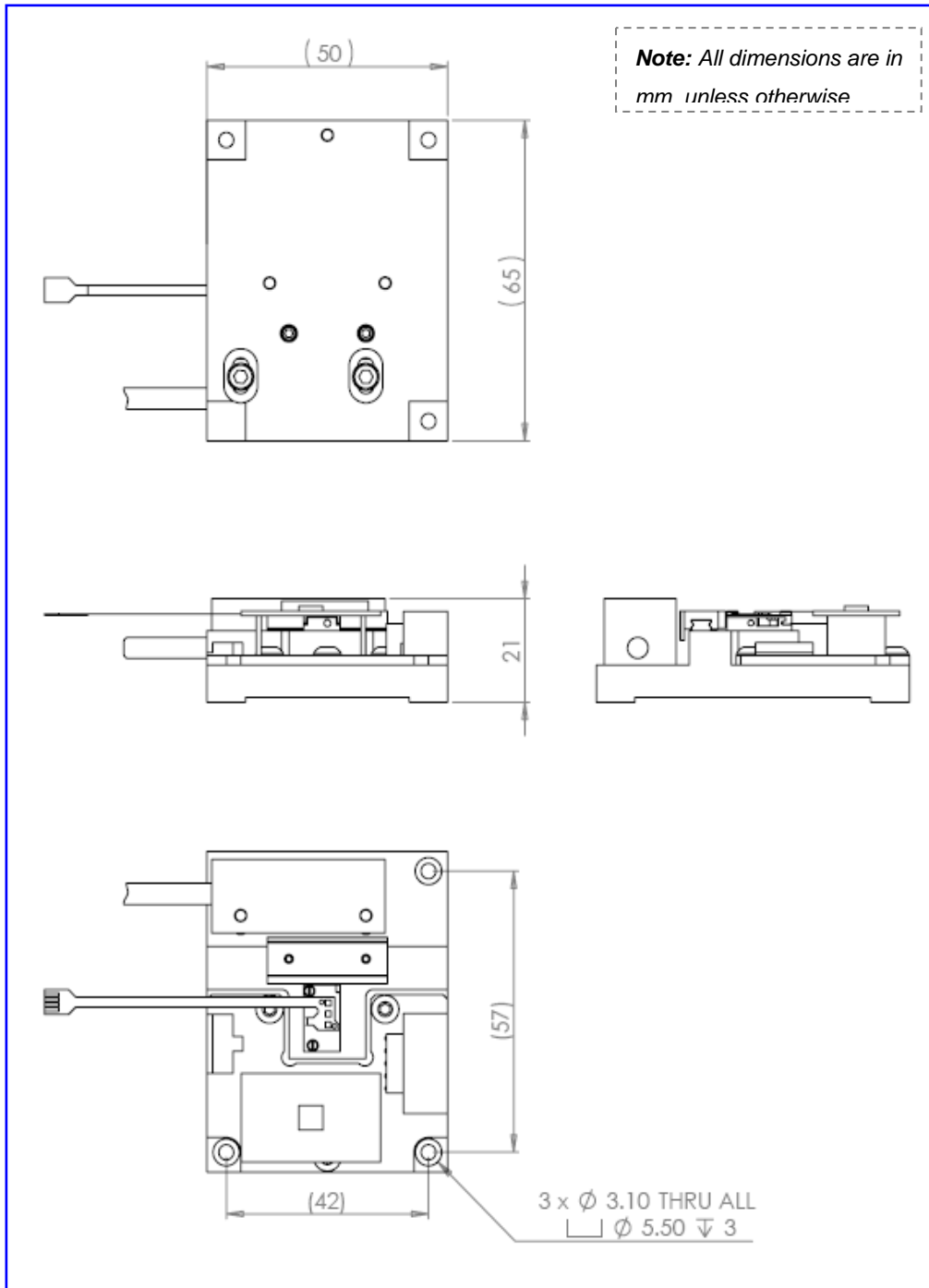

**Figure 12: Linear Slide Properties**

| Description    | Value |
|----------------|-------|
| B <sub>1</sub> | 4     |
| B              | 7     |
| A              | 4     |
| d <sub>1</sub> | M1.6  |
| H              | 20    |
| L              | 25    |
| L <sub>3</sub> | 1x16  |
| L <sub>4</sub> | 4.5   |
| s              | 2.1   |
| t              | 1.5   |
| x              | 1.1   |
| Weight in g    | 5     |

**Table 3: Linear Slide Properties Parameters**

## 4.4 Motion Module Layout



**Figure 13: Motion Module Layout**

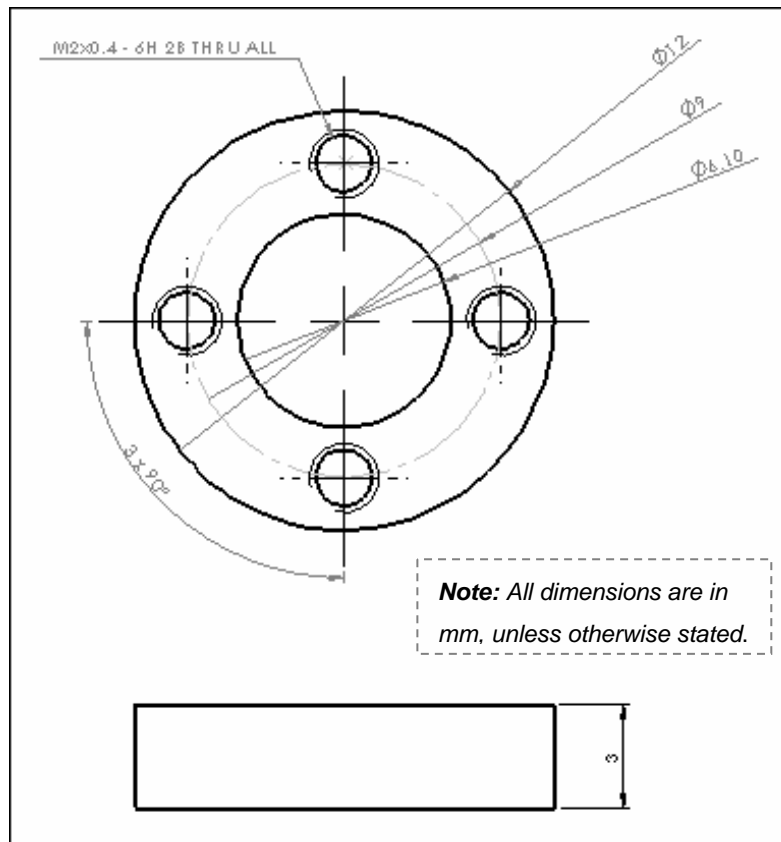

**Figure 14: Rotary Mounting Ring for Motion Module**

## 5 Ordering Information

### 5.1 Part Numbering Scheme

There are four available configurations for the EDGE Evaluation Kit:

| Product             | Options               |   |
|---------------------|-----------------------|---|
| EDGE Evaluation Kit | Linear / Rotary Slide | Encoder   |
| EDGE-EVAL-          | LS<br>RS*             | RE = Renishaw 0.1µ encoder<br>ME = Micro-E encoder adaptor<br>0E = no encoder (open loop) |

**Note:**

- *RS configuration is available only with 0E option.*

### 5.2 Example Configurations

- EDGE Evaluation Kit with rotary slide - open loop.

|            |    |    |
|------------|----|----|
| EDGE-EVAL- | RS | 0E |
|------------|----|----|

- EDGE Evaluation Kit with linear slide and Micro-E encoder adaptor.

|            |    |    |
|------------|----|----|
| EDGE-EVAL- | LS | ME |
|------------|----|----|

## 6 Contact Information

---

### 6.1 Customer Service

Contact your local distributor or email Nanomotion Ltd. Technical Support Department at [techsupport@nanomotion.com](mailto:techsupport@nanomotion.com), with detailed problem description, additions, corrections or suggestions.

### 6.2 General Inquiries and Ordering

- **Outside the USA**

Nanomotion Ltd. Headquarters

Nanomotion Ltd.

PO Box 223

Yokneam, Israel 20692

Tel: + 972-73-2498065

Fax: + 972-73-2498099

Web site: [www.nanomotion.com](http://www.nanomotion.com)

Email: [nano@nanomotion.com](mailto:nano@nanomotion.com)

- **In the USA**

Nanomotion Inc. (US) Headquarters

Nanomotion Inc

1 Comac Loop, Ste. 14B2

Ronkonkoma, NY 11779

Tel: (800) 821-6266

Fax: (631) 585-1947

Web site: [www.nanomotion.com](http://www.nanomotion.com)

Email: [nanous@nanomotion.com](mailto:nanous@nanomotion.com)